

EPA/540/2-88/004
September 1988

Technology Screening Guide for Treatment of CERCLA Soils and Sludges

Office of Solid Waste and Emergency Response
Office of Emergency and Remedial Response
U.S. Environmental Protection Agency
401 M Street, S.W.
Washington, D.C. 20460

U.S. Environmental Protection Agency
Office of Emergency and Remedial Response
401 M Street, S.W.
Washington, D.C. 20460

DISCLAIMER

This guide has been reviewed in accordance with the U.S. Environmental Protection Agency's peer and administrative review policies and approved for presentation and publication. Mention of trade names or commercial products does not constitute endorsement or recommendation for use.

FOREWORD

The Environmental Protection Agency is committed to a broader use of treatment technologies for the management of Superfund waste. These technologies provide permanent long-term remedies which serve as alternatives to land disposal. However, our experience with these techniques for soils and sludges is somewhat limited, and relatively few technologies are considered to be fully developed and available for common use. In order to meet the goals contained in the 1986 Superfund amendments, the Agency must rely on technologies which are currently innovative and require further testing and development before they are readily available for use.

This document provides a framework to assist the evaluation of technologies in the Superfund program. The guide provides basic information to initially screen technologies applicable to a given Superfund site or waste. This screening helps to identify the information required to further evaluate the treatment technologies, most of which are innovative at this time.

The program encourages the use of these innovative technologies and promotes their evaluation when they appear to promise better performance, easier implementability, fewer adverse impacts, or lower costs than more proven technologies. Relative to other, more established technologies, it is particularly important to conduct treatability studies for innovative approaches during the remedial investigation/feasibility study process and to carefully consider scale-up factors.

We hope this guide will serve as a useful reference. Additional copies of the report may be obtained at no charge from EPA's Center for Environmental Research Information, 26 West Martin Luther King Drive, Cincinnati, Ohio, 45268, using the EPA document number found on the report's front cover. Once this supply is exhausted, copies can be purchased from the National Technical Information Service, Ravensworth Bldg., Springfield, VA, 22161, (702) 487-4600. Reference copies will be available at EPA libraries in their Hazardous Waste Collection.



Thomas W. Devine, Director
Office of Program Management
and Technology

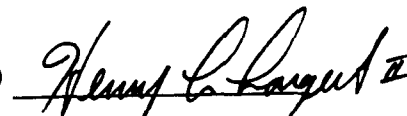

Henry L. Longest II, Director
Office of Emergency and
Remedial Response

PREFACE

This guide is intended to disseminate information on technologies available at this time for treating CERCLA wastes in soils and sludges. The technology data were obtained from individual treatment technology vendors. The data have been reviewed by representatives of the U.S. Environmental Protection Agency's Office of Emergency and Remedial Response, Office of Solid Waste, and Office of Research and Development.

ABSTRACT

The Technology Screening Guide for Treatment of CERCLA Soils and Sludges is a guide for screening feasible alternative treatment technologies for soils and sludges at Superfund sites. The guide provides a screening methodology to identify treatment technologies that may be suitable for the management of soils and sludges containing CERCLA wastes.

A simplified screening methodology flowchart presents the decision steps necessary to identify suitable treatment technologies, while the waste/technology matrix tables included in this guide can be used to ascertain whether the treatment technologies have demonstrated effectiveness, potential effectiveness, or no effectiveness in the treatment of organic, inorganic, and reactive wastes or whether the technologies could adversely impact the environment.

For each of the treatment technologies, information is presented on (a) the generic system, (b) individual, unique systems, (c) developmental status, (d) process schematics, (e) characteristics affecting treatment performance, and (f) contacts. Some limited information is also presented about pretreatment, materials handling, and residuals management requirements.

TABLE OF CONTENTS

Section	Page No.
EXECUTIVE SUMMARY	1
1 INTRODUCTION	3
2 USING THIS GUIDE	7
2.1 Waste Characteristics	7
2.1.1 Waste Matrix	7
2.1.2 Waste Constituents	9
2.1.3 Other Characteristics Impacting Technology Applicability	9
2.2 Waste/Technology Tables	9
2.3 Technology Restriction Tables	15
2.4 Pretreatment Tables	16
2.5 Examples for Using this Guide	22
2.5.1 Example for a Single Waste Group	22
2.5.2 Example for Multiple Waste Groups	22
3 APPLICATION OF THIS GUIDE TO A HYPOTHETICAL WASTE	25
APPENDICES	31
APPENDIX A. THERMAL TREATMENT TECHNOLOGIES	33
Introduction	33
A.1 Fluidized Bed Incineration	35
A.2 Rotary Kiln Incineration	40
A.3 Infrared Thermal Treatment	43
A.4 Wet Air Oxidation	47
A.5 Pyrolytic Incineration	52
A.6 Vitrification	55
References	60
APPENDIX B. PHYSICAL/CHEMICAL TREATMENT TECHNOLOGIES	61
Introduction	61
B.1 Chemical Extraction	63
B.2 In Situ Chemical Treatment	68
B.3 Soil Washing	72
B.4 In Situ Soil Flushing	77
B.5 Glycolate Dechlorination	80

Section	Page No.
B.6 Low Temperature Thermal Stripping	83
B.7 In Situ Vacuum and Steam Extraction	86
B.8 Stabilization/Solidification	90
B.9 Chemical Reduction-Oxidation	95
B.10 In Situ Vitrification	98
References	102
APPENDIX C. BIOLOGICAL TREATMENT TECHNOLOGIES	103
Introduction	103
C.1 Biodegradation	104
C.1.1 Composting	104
C.1.2 Slurry-Phase Treatment	104
C.1.3 Solid-Phase Treatment	105
C.2 In Situ Biodegradation	111
References	116
APPENDIX D. SELECTED REFERENCE TABLES	117

FIGURES

Figure No.		Page No.
1	Screening Methodology Flowchart	8
2	Technology Screening Procedure for a Hypothetical Waste .	26
A.1-1	Fluidized Bed Incineration	37
A.1-2	Circulating Bed Combustor	38
A.2-1	Rotary Kiln Incineration	41
A.3-1	Infrared Thermal Treatment	45
A.4-1	Wet Air Oxidation	49
A.4-2	Supercritical Water Oxidation Unit	50
A.5-1	Pyrolytic Incineration System	53
A.6-1	Vitrification ("Electric Pyrolyzer")	57
A.6-2	Vitrification ("Pyrolytic Centrifugal Reactor")	58
B.1-1	Chemical Extraction ("BEST")	65
B.1-2	Critical Fluid Solvent Extraction	66
B.2-1	In Situ Chemical Treatment ("Detoxifier")	70
B.3-1	Soil Washing System	74
B.3-2	Soil Washing	75
B.4-1	In Situ Soil Flushing	78
B.5-1	Glycolate Dechlorination	81
B.6-1	Low Temperature Thermal Stripping	84
B.7-1	In Situ Vacuum Extraction	88
B.8-1	Stabilization/Solidification	92
B.9-1	Chemical Reduction-Oxidation	96
B.10-1	In Situ Vitrification	100
C.1-1	Slurry-Phase Biodegradation	107
C.1-2	Solid-Phase Biodegradation	108
C.2-1	In Situ Biodegradation	113

Table No.		Page No.
1	Examples of Constituents Within Waste Groups	10
2	Waste/Technology Matrix: Soils	13
3	Waste/Technology Matrix: Sludges	14
4	Pretreatment/Materials Handling Table: Sludges	17
5	Pretreatment/Materials Handling Table: Soils	18
6	Residuals Management	20
A-1	High Temperature Thermal Treatment (General)--Soils and Sludges	34
A.1-1	Fluidized Bed Incineration--Soils and Sludges	39
A.2-1	Rotary Kiln Incineration--Soils and Sludges	42
A.3-1	Infrared Thermal Treatment--Soils and Sludges	46
A.4-1	Wet Air Oxidation--Sludges	51
A.5-1	Pyrolytic Incineration--Soils and Sludges	54
A.6-1	Vitrification--Soils and Sludges	59
B.1-1	Chemical Extraction - Soils and Sludges	67
B.2-1	In Situ Decontamination--Soils and Sludges	71
B.3-1	Soil Washing--Soils	76
B.4-1	In Situ Soil Flushing--Soils	79
B.5-1	Glycolate Dechlorination--Soils and Sludges	82
B.6-1	Low Temperature Thermal Stripping--Soils	85
B.7-1	In Situ Vacuum and Steam Extraction--Soils	89
B.8-1	Stabilization/Solidification--Soils and Sludges	93
B.9-1	Chemical Reduction-Oxidation--Sludges	97
B.10-1	In Situ Vitrification--Soils and Sludges	101
C.1-1	Biodegradation--Soils and Sludges	109
C.2-1	In Situ Biodegradation--Soils and Sludges	114
D.1	Examples of Constituents Within Waste Groups	118
D.2	Waste/Technology Matrix: Soils	121
D.3	Waste/Technology Matrix: Sludges	122
D.4	Pretreatment/Materials Handling Table: Sludges	123
D.5	Pretreatment/Materials Handling Table: Soils	124
D.6	Residuals Management	126

ACKNOWLEDGMENTS

This guide was prepared by Tim Holden, John Newton, Paul Sylvestri, and Max Diaz of Versar Inc., Springfield, Virginia, and Colin Baker of Camp, Dresser & McKee of Boston, Massachusetts, for the U.S. Environmental Protection Agency in fulfillment of Contract 68-01-7053. Editing and technical content of this report were the responsibilities of the contractor. This document should not be viewed as a statement of Agency policy.

The authors wish to acknowledge the assistance of several individuals and organizations that have made significant contributions to this study of hazardous waste treatment and management. This includes the exceptional guidance and review of drafts during the study provided by Linda Galer, John Kingscott, and Don White of the Office of Emergency and Remedial Response. Substantial contributions were made during data collection and document review by the Office of Solid Waste, including members of the Waste Treatment Branch, and by the Office of Research and Development's Risk Reduction Engineering Laboratory in Cincinnati, Ohio.

We would like to recognize the data gathering and collection efforts provided by Camp, Dresser & McKee, in particular the work of Colin Baker.

The authors would like to express particular gratitude to the Versar production team, including the editors headed by Juliet Crumrine, and particularly Martha Martin, the typists, and the artists for their many long hours producing the numerous drafts of this extensive report.

Finally, the authors would like to acknowledge the members of the study team who played such an important role in assembling these data, developing the methodology, and preparing the technology writeups.

Study Team

Linda Galer	EPA Work Assignment Manager
Tim Holden	Versar Task Manager
John Newton	Principal Investigator
Paul Sylvestri	Study Engineer
Maximo Diaz	Study Engineer
Thomas Drygas	Engineering Review - Thermal Treatment Technologies
Rajani Joglekar	Engineering Review - Physical/Chemical and Biological Treatment Technologies
Jerome Strauss	Versar Program Manager

EXECUTIVE SUMMARY

This document is a guide for the screening of alternative treatment technologies for contaminated *soils* and *sludges* at CERCLA sites. The guide has been developed to help those responsible for remedy selection to identify potentially applicable treatment systems for the remediation of uncontrolled hazardous waste sites. It contains technical information useful for determining the feasibility and availability of 18 different treatment technologies without consideration of cost. Some of the technologies are still innovative, are not fully developed, and are not available for immediate use. This guide is intended for use as a screening tool to facilitate the scoping of site investigations and feasibility studies. This guide is not a substitute for in-depth engineering analyses.

The application of many of the innovative technologies discussed here has not been fully established. Therefore, judgment was often required to assess technology applicability and limiting factors. Some readily available references were used; however, an exhaustive literature search was beyond the scope of this effort.

Included in the first part of this document are a methodology and accompanying matrices that can be used to screen wastes for feasible treatment technologies. The screening can be performed for both wastes in soils and wastes as sludges. Liquid wastes are not addressed directly; however, liquids produced in the treatment process are identified, and associated information on residuals management is provided in a table. Informational tables on waste pretreatment and materials handling for soils and sludges are also provided. The result of the technology screening will be a list of potentially feasible treatment options for the waste.

Appendices A, B, and C present information on the individual treatment technologies that could appear on the screening list. For each technology, the document presents a brief description of the generic process; information on individual, available systems, including unique capabilities; a discussion of parameters that can affect system operation; and a listing of selected EPA contacts and vendors. Generic flow diagrams of technologies or, where available, diagrams of specific systems are presented. Finally, for each technology, a table is provided that lists waste characteristics impacting process performance, the reasons that the characteristics may restrict operation, and types of analyses needed to identify the presence of such characteristics. This information can be used to develop plans for site sampling and analysis. The table also gives references that provide additional information about the potential problem.

Where available, quantitative data on restrictive characteristics have been included in the tables to assist the user in evaluating potential technologies. The data have been extracted from sources addressing the technology generically and from sources, including vendors, that describe a specific treatment system. The data should be used only as guidelines, they may not be transferable to every application and are not intended as a substitute for case-specific assessments by qualified professionals.

The guide can be used iteratively to further refine technology options as additional data are obtained. However, this guide is designed only to assist in screening alternative technologies and in identifying the data collection requirements needed to evaluate technical feasibility. The applicability and availability of potential technologies thus identified must be further evaluated by using the references provided, contacting technology experts (including vendors), performing bench and/or pilot testing as necessary, and considering site-specific circumstances on a case-by-case basis. Treatability testing may be required to determine the applicability of some technologies. This is particularly true for the innovative, undemonstrated technologies and technologies whose effectiveness is highly dependent on the characteristics of the waste.

Section 1 Introduction

In the Superfund Amendments and Reauthorization Act of 1986 (SARA), Congress directed the U.S. Environmental Protection Agency (EPA) to promote the development of alternative and innovative treatment technologies for use in Superfund response actions. Similarly, the Hazardous and Solid Waste Amendments of 1984 (HSWA) to the Resource Conservation and Recovery Act (RCRA) emphasize the treatment of hazardous waste through the phased prohibition of land disposal of untreated hazardous wastes. Therefore, Congress has clearly directed the Agency to reduce the reliance on land disposal of wastes through the development and increased use of alternative treatment technologies.

This guide for the screening of treatment alternatives for soils and sludges has been developed to help identify potentially applicable treatment technologies for the remediation of uncontrolled hazardous waste sites. The guide is not designed to serve as the sole basis for selection of a technology for a particular waste, but rather to identify the treatment technologies potentially applicable to that waste based on technical feasibility, not cost. Information on widely available, commercially demonstrated technologies (e.g., incineration) as well as undemonstrated innovative technologies (e.g., in situ soil flushing) has been included in this guide. Judgment was often required to assess the applicability of these newer techniques. Furthermore, some readily available references were used, but the scope of the document did not include a thorough literature search. Therefore, this guide is intended for use as a reference and is not intended to replace the judgment of qualified professionals. Each situation must be addressed on a case-by-case basis, considering the site-specific circumstances and the status of technologies as they develop over time.

This guide does not evaluate treatment technologies for liquid wastes but focuses instead on soils and sludges, for which the greatest innovation and challenge currently exist. However, the management of liquid residuals from the treatment of soils and sludges is addressed.

Screening is accomplished by use of waste/technology tables and technology restriction tables. These are used to analyze potentially applicable technologies by:

1. Identifying treatment units potentially applicable to the remediation of the many types of waste found at CERCLA sites; and
2. Identifying interfering waste and/or site characteristics, treatment process limitations, pretreatment options, and management of treatment residuals, all of which must be considered when evaluating a potential treatment system in detail.

The above information is provided in four groups of tables:

(1) waste/technology tables for sludges and soils, (2) technology restriction tables for all the technologies, (3) pretreatment tables to identify potential pretreatment and materials-handling systems, and (4) a residuals management table. The tables are designed to be used by both technical and nontechnical personnel with a general scientific background.

The guide also identifies for some technologies an EPA contact who is familiar with the operation and limitations associated with the technology. A complete reference of knowledgeable individuals within and outside of EPA is beyond the scope of this document.

In addition, for those technologies that have only one or a few developers, the company name and contact for some of the "vendors" have been included to assist the user in gathering additional information about the technologies' limitations and/or applicability, availability, and cost. Inclusion of a developer in this guide in no way implies an EPA endorsement of the technology or developer. Developers have been included only to assist users in screening potentially applicable technologies. Furthermore, a comprehensive listing of all vendors offering the technologies discussed was beyond the scope of this document.

The principal information provided in this guide is contained in the technology restriction tables. These tables assist in identifying waste, site, and technology factors that should be considered in the evaluation or implementation of treatment systems. Specifically, the tables identify the data necessary for a more detailed evaluation of the technologies. Once these data are collected, the guide can be used to focus on potentially applicable technologies warranting further evaluation. A more detailed analysis of each potentially applicable treatment alternative identified by this guide would include assessments of cost, performance, and environmental impacts and the availability of full-scale commercial units. In particular, bench- and/or pilot-scale treatability studies may be required before the actual applicability and performance of many technologies can be determined. This guide is not meant to be used for such in-depth analyses; it is designed to provide a preliminary screening of treatment alternatives and to identify data needs.

The initial step in using this guide is to determine whether the waste is a soil or sludge and to identify the contaminants requiring treatment. This information allows the user to place the waste into broad waste groups using Table 1. Next, technologies with demonstrated or potential effectiveness on the waste groups can be identified using Table 2 or 3. Each technology can then be further evaluated and data needs identified by referring to the technology description and the technology restriction table that follows each description. The effectiveness values shown in Tables 2 and 3 are based on the characteristics affecting performance that are described in the technology writeups. It is important to note that modifications to technologies and/or pretreatment of the waste may preclude restrictions to the use of a treatment.

The pretreatment tables (Tables 4 and 5) identify potential techniques to make the waste more amenable to treatment. Many wastes require pretreatment prior to the use of a principal treatment method. It is important to assess the potential for waste pretreatment before eliminating a principal technology from consideration. Finally, the residuals management table (Table 6) outlines general options for handling potential treatment residuals.

When using Table 1 to evaluate wastes that can be placed into two or more groups (i.e., complex wastes), each waste group should initially be treated separately to develop a list of potentially applicable treatment technologies. The technology lists can then be compared to determine if

one technology can treat all the waste groups or whether a sequence of treatments (i.e., treatment train) may be required. Treatment train development is discussed in further detail in Sections 2.5 and 3. As the user obtains more information about waste characteristics, this guide can be used to help further refine the list of potentially applicable technologies. As stated earlier, however, the guide is intended for use as a reference only and does not contain sufficient information to fully evaluate treatment technologies.

The contents of this guide are organized into three sections and four appendices as follows:

- Section 2 describes how to use this guide by outlining the waste characterization process; describing the waste/technology tables and explaining how the effectiveness of the technologies was determined; discussing the content and utility of the technology restriction tables; summarizing the purpose and use of the pretreatment tables and residuals management table; and presenting a step-by-step approach for the proper use of this guide.
- Section 3 illustrates how to use the guide by working through a technology screening for a hypothetical waste.
- Appendix A describes thermal treatment technologies and includes a list of applicable references.
- Appendix B describes chemical/physical treatment technologies and includes a list of applicable references.
- Appendix C describes biological treatment technologies and includes a list of applicable references.

For each technology a generic description is presented, followed by examples and illustrations of systems provided by individual vendors. Note that the illustrations are only examples; in most cases, many configurations and add-ons are possible.

- Appendix D repeats several key tables for easy reference.

Section 2 Using This Guide

To use this guide to screen potentially applicable technologies, the user must first determine whether the waste of concern is a sludge or soil and must identify the contaminants that require treatment. The guide then provides information that facilitates the selection of technologies that may apply to the site and identifies the additional data required to further evaluate these technologies. This approach allows the screening of technologies early in the study of a site and the identification of data needs that should be considered in the scoping of the site sampling plan and site feasibility studies. For instance, the potential need for treatability studies can be assessed.

The screening methodology for selecting potential technologies is shown as Figure 1. Generally, the methodology involves:

- Identification of waste constituents (see Section 2.1);
- Selection of effective or potentially effective technologies from the appropriate tables for the identified waste constituents (see Section 2.2);
- Generation of a list of all potential technologies for the entire waste;
- Review of the technology writeups to determine how well the technology may be expected to perform (see Section 2.3 and the appendices);
- Determination of pretreatment and residuals management needs (see Section 2.4); and
- Identification of data collection needs and requirements for treatment testing.

Simple examples of how to implement the methodology for single and multiple wastes are provided at the end of this section.

2.1 Waste Characteristics

In order to conduct even a preliminary screen of technologies, wastes must be categorized by certain fundamental characteristics. The two principal waste characteristics used in this guide for initial technology screening are waste matrix and waste constituents. Once technologies have been identified based on matrix and constituents, further screening is possible using other waste characteristics impacting technology applicability and performance. These further waste attributes are identified in the technology summaries.

2.1.1 Waste Matrix

Moisture content appears to be a key factor in distinguishing how soils, sludges, and liquids can be treated and handled. Thus, this guide uses moisture content to determine whether the waste should be considered a soil or a sludge. It is recognized that many varying definitions can be used

Figure 1. Screening methodology flowchart.

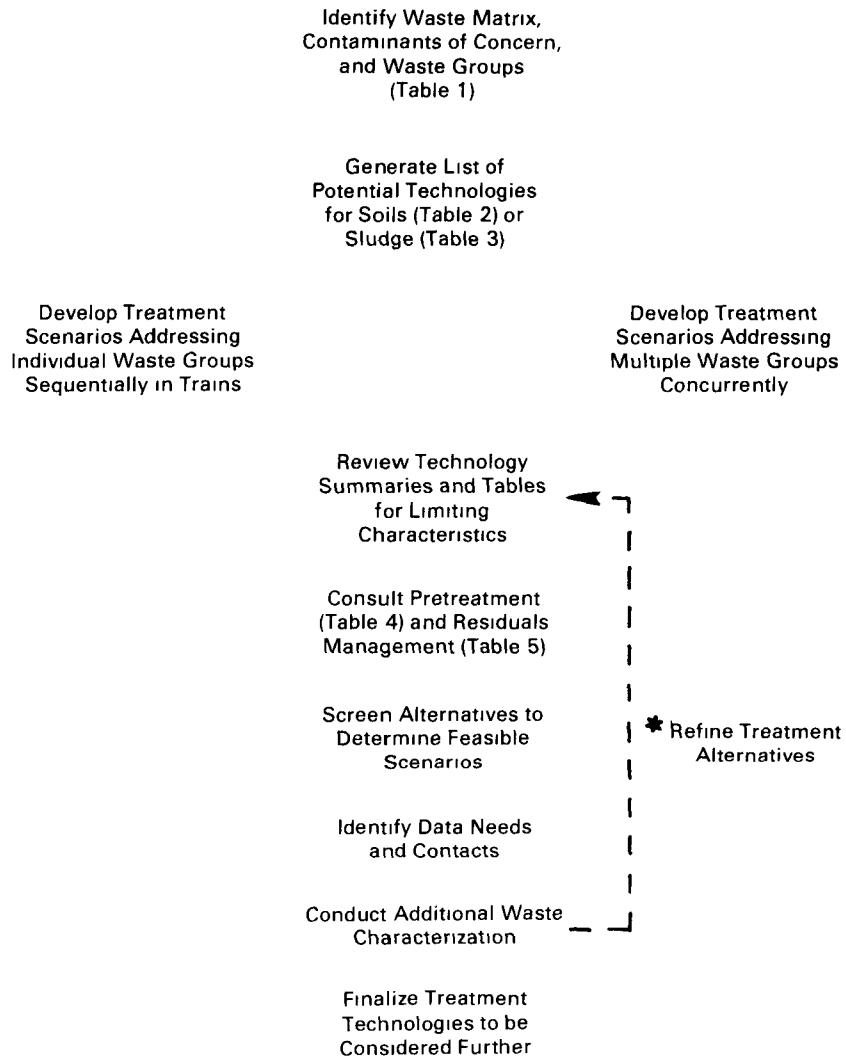

for soils and sludges, but for the purpose of this guide, sludges are defined as pumpable materials of both natural and man-made origin with a solids content ranging from 10 to 85 percent. Wastes with a water content greater than 90 percent are considered liquids. Furthermore, for the purpose of this document, soils are naturally occurring earth materials, not meant to include end-of-pipe manufacturing wastes. Generally, soils have a moisture content of 10 to 20 percent or less. It should be noted that the EPA has other definitions for these matrices derived for other purposes.

2.1.2 Waste Constituents

Chemical constituents are the second basis for characterizing waste treatability so that technologies can be screened. Chemical constituents can be grouped in general categories according to their chemical nature (e.g., organics and metals). Table 1 provides examples of waste constituents within a waste group. These waste groups provide the basis for selecting potential treatment technologies. It is important to note, however, that categorizing constituents by waste group may oversimplify treatability categories. For some technologies such as biodegradation, treatability of compounds within a waste group may differ substantially. In addition, contaminated soils and sludges often contain more than one waste group; to use the guide properly, all waste groups requiring treatment must be identified.

2.1.3 Other Characteristics Impacting Technology Applicability

Other waste characteristics and site factors can influence treatability. Discussions of the impact of these factors on treatability are contained in the technology restriction tables provided in the appendices. Examples of key waste characteristics affecting treatability for soils treatment include: grain size, organic content, pH, moisture content, soil/solvent reactions, metals content, and the presence of various elements in the soil.

As an example, grain size affects most of the soil treatment technologies. For soil washing and in situ soil flushing, homogeneous soil is desirable because inconsistent flushing generally occurs in soil with highly variable grain size. Stabilization also can be affected by grain size. Silt and clay, which contain grain sizes of less than 0.0625 mm, (<200 sieve mesh) may coat large contaminants like a dust layer, thereby weakening bonds formed during the stabilization process. Soils of low permeability (i.e., soils of high silt or clay content) can cause reduced percolation and leaching capabilities, as well as reduced solid/liquid separation in soil washing or flushing.

Organic content is another important characteristic in the screening of treatment technologies. Organic content can affect the performance of cement-based stabilization by reducing the binding capacity of the fixative and may cause premature structural degradation. Decomposition of organic material can also result in increased permeability of the final product in stabilization/solidification processes. Excessive organic content can affect soil washing and flushing as well, by inhibiting the desorption of contaminants.

2.2 Waste/Technology Tables

This guide contains two waste/technology tables, Table 2 for soils and Table 3 for sludges, designed to identify the effectiveness and/or potential applicability of technologies to some or all compounds within specific waste groups. The waste/technology tables assume that the user has characterized the waste by matrix, principal contaminants, and waste

Table 1 **Examples of Constituents Within Waste Groups.**

HALOGENATED VOLATILES	HALOGENATED SEMIVOLATILES (cont)
Bromodichloromethane	Bis(2-chloroethoxy)phthalate
Bromoform	Bis(2-chloroethoxy)ether
Bromomethane	1,2-bis(2-chloroethoxy)ethane
Carbon tetrachloride	
Chlorodibromomethane	NONHALOGENATED VOLATILES
Chlorobenzene	Acetone
Chloroethane	Acrolein
Chloroform	Acrylonitrile
Chloromethane	Benzene
Chloropropane	2-butanone
Dibromomethane	Carbon disulfide
Cis,1,3-dichloropropene	Cyclohexanone
1,1-Dichloroethane	Ethyl acetate
1,2-Dichloroethane	Ethyl ether
1,1-Dichloroethene	Ethyl benzene
1,2-Dichloroethene	2-hexanone
1,2-Dichloropropane	Isobutanol
Fluorotrichloromethane	Methanol
Methylene chloride	Methyl isobutyl ketone
1,1,2,2-tetrachloroethane	4-methyl-2-pentanone
Tetrachloroethene	n-butyl alcohol
1,1,1-Trichloroethane	Styrene
1,1,2-Trichloroethane	Toluene
1,2-Trans-dichloroethene	Trimethyl benzene
Trans-1,3-dichloropropene	Vinyl acetate
1,1,2-trichloro-1,2,2-trifluoroethane	Xylenes
Trichloroethene	
Vinyl chloride	NONHALOGENATED SEMIVOLATILES
Total chlorinated hydrocarbons	Benzoic acid
Hexachloroethane	Cresols
Dichloromethane	2,4-dimethylphenol
	2,4-dinitrophenol
HALOGENATED SEMIVOLATILES	2-methylphenol
2-chlorophenol	4-methylphenol
2,4-dichlorophenol	2-nitrophenol
Hexachlorocyclopentadiene	4-nitrophenol
p-chloro-m-cresol	Phenol
Pentachlorophenol	Acenaphthene
Tetrachlorophenol	Acenaphthylene
2,4,5-trichlorophenol	Anthracene
2,4,6-trichlorophenol	Benzidine
Bis-(2-chloroethoxy)methane	Benzo(a)anthracene
Bis(2-chloroethyl)ether	Benzo(b)fluoranthene
Bis(2-chloroisopropyl)ether	Benzo(k)fluoranthene
4-bromophenyl phenyl ether	Benzo(a)pyrene
4-chloroaniline	Benzo(ghi)perylene
2-chloronaphthalene	Benzyl alcohol
4-chlorophenyl phenylether	Bis(2-ethylhexyl)phthalate
1,2-dichlorobenzene	Butyl benzyl phthalate
1,3-dichlorobenzene	Chrysene
1,4-dichlorobenzene	Dibenzo(a,h)anthracene
3,3-dichlorobenzidine	Dibenzofuran
Hexachlorobenzene	Diethyl phthalate
Hexachlorobutadiene	Dimethyl phthalate
1,2,4-trichlorobenzene	Di-n-butyl phthalate

Table 1 *Examples of Constituents Within Waste Groups (continued).*

4,6-dinitro-2-methylphenol	VOLATILE METALS (cont)
2,4-dinitrotoluene	Lead
2,6-dinitrotoluene	Mercury
Di-n-octyl phthalate	Tin
1,2-diphenylhydrazine	Selenium
Fluoranthene	
Fluorene	OTHER CATEGORIES
Indeno(1,2,3-cd)pyrene	Asbestos
Isophorone	
2-methylnaphthalene	INORGANIC CORROSIVES
Napthalene	Hydrochloric acid
2-nitroaniline	Nitric acid
3-nitroaniline	Hydrofluoric acid
4-nitroaniline	Sulfuric acid
Nitrobenzene	Sodium hydroxide
n-nitrosodimethylamine	Calcium hydroxide
n-nitrosodi-n-propylamine	Calcium carbonate
n-nitrosodiphenylamine	Potassium carbonate
Phenanthrene	
Pyrene	PCBs
Pyridine	PCB (Arochlor)-1016
2-methylnaphthalene	PCB (Arochlor)-1221
Bis phthalate	PCB (Arochlor)-1232
Phenyl naphthalene	PCB (Arochlor)-1242
	PCB (Arochlor)-1248
	PCB (Arochlor)-1254
	PCB (Arochlor)-1260
	PCB NOS (not otherwise specified)
PESTICIDES	
Aldrin	
Bhc-alpha	
Bhc-beta	
Bhc-delta	
Bhc-gamma	ORGANIC CORROSIVES
Chlordane	Acetic acid
4,4'-DDD	Acetyl chloride
4,4'-DDE	Aniline
4,4'-DDt	Aromatic Sulfonic acids
Dieldrin	Cresylic acid
Endosulfan I	Formic acid
Endosulfan II	
Endosulfan sulfate	NONMETALLIC TOXIC ELEMENTS
Endrin	Fluorine
Endrin aldehyde	Bismuth
Ethion	
Ethyl parathion	NONVOLATILE METALS
Heptachlor	Aluminum
Heptachlor epoxide	Antimony
Malathion	Barium
Methylparathion	Beryllium
Parathion	Bismuth
Toxaphene	Cadmium
	Calcium
	Chromium
	Copper
	Cobalt
VOLATILE METALS	Iron
Arsenic	Magnesium
Bismuth	

Table 1 **Examples of Constituents Within Waste Groups (continued).**

<i>NONVOLATILE METALS (cont)</i>	<i>ORGANIC CYANIDES</i>
<i>Manganese</i>	<i>Organonitriles</i>
<i>Nickel</i>	
<i>Potassium</i>	<i>INORGANIC CYANIDES</i>
<i>Selenium</i>	<i>Cyanide</i>
<i>Sodium</i>	<i>Metallic cyanides</i>
<i>Vanadium</i>	<i>(e.g., ferricyanide,</i>
<i>Zinc</i>	<i>sodium cyanide)</i>
	<i>OXIDIZERS</i>
<i>RADIOACTIVES</i>	<i>Chlorates</i>
<i>Radioactive isotopes of</i>	<i>Chromates</i>
<i>iodine, barium, uranium</i>	
<i>Radium</i>	<i>REDUCERS</i>
<i>Gamma radioactivity</i>	<i>Sulfides</i>
<i>Radon; alpha radioactivity</i>	<i>Phosphides</i>
	<i>Hydrazine</i>

groups (Table 1). The waste groups are listed vertically down the left margin, and the technologies are listed horizontally across the top of each table.

The waste groups in the waste/technology tables are organized in a manner that generally reflects similar treatability characteristics (e.g., volatility, biodegradability, heating value). Certain contaminants such as PCBs and pesticides are presented separately from other halogenated organics for easy reference.

Some of the technologies included in this guide may be used primarily for volume reduction, waste separation, or other pretreatment and may not completely treat or destroy the constituents of concern (e.g., chemical extraction). They have been included because they represent a significant step in the overall management of a waste.

The following descriptors are used to characterize the applicability of the technologies to each waste group:

1. Demonstrated effectiveness - (Symbol ●). The technology has been used successfully on a commercial scale for treating CERCLA wastes in repeated applications (e.g., rotary kiln incineration of most organics).
2. Potential effectiveness - (Symbol ◐). The technology appears to have the basic characteristics needed for successful application but has not been proven for specific CERCLA wastes on a commercial scale or on a continuous basis. That is, successful treatment technology tests of (1) RCRA wastes or other CERCLA wastes on a commercial scale or (2) CERCLA wastes on a demonstration or pilot scale, indicate potential effectiveness of the technology. In many cases the commercial technology will require further demonstration and development before it is ready for use in site remediation. Effectiveness may depend on specific waste or soil characteristics (e.g., soil flushing of organics depends on soil permeability), or pretreatment may be required. The potential for negative impacts on the environment is uncertain and should be evaluated on a case-by-case basis. A decision on feasibility requires careful consideration of waste-related limitations (i.e., waste characteristics that affect performance) or mixture interferences and may

Table 2 Waste Technology Matrix: Soils.

Contaminant		Technology																	
		A.1-1	A.2-1	A.3-1	A.5-1	A.6-1	B.1-1	B.2-1	B.3-1	B.4-1	B.5-1	B.6-1	B.7-1	B.8-1	B.10-1	C.1-1	C.2-1		
Organic	Halogenated volatiles	●	●	●	●	●	●	●	●	●	●	●	●	●	●	●	●	●	
	Halogenated semivolatiles	●	●	●	●	●	●	●	●	●	●	●	●	●	●	●	●	●	
	Nonhalogenated volatiles	●	●	●	●	●	●	●	●	●	●	●	●	●	●	●	●	●	
	Nonhalogenated semivolatiles	●	●	●	●	●	●	●	●	●	●	●	●	●	●	●	●	●	
	PCBs	●	●	●	●	●	●	●	●	●	●	●	●	●	●	●	●	●	
	Pesticides	●	●	●	●	●	●	●	●	●	●	●	●	●	●	●	●	●	
	Organic cyanides	●	●	●	●	●	●	●	●	●	●	●	●	●	●	●	●	●	
	Organic corrosives	●	●	●	●	●	●	●	●	●	●	●	●	●	●	●	●	●	
	Inorganic	Volatile metals	×	×	×	○	×	○	○	○	○	○	○	○	○	○	○	○	○
		Nonvolatile metals	○	○	○	○	○	○	○	○	○	○	○	○	○	○	○	○	○
Asbestos		○	○	○	○	○	○	○	○	○	○	○	○	○	○	○	○	○	
Radioactive materials		○	○	○	○	○	○	○	○	○	○	○	○	○	○	○	○	○	
Inorganic corrosives		○	○	○	○	○	○	○	○	○	○	○	○	○	○	○	○	○	
Inorganic cyanides		○	○	○	○	○	○	○	○	○	○	○	○	○	○	○	○	○	
Reactive	Oxidizers	●	●	●	●	●	○	○	○	○	○	○	○	○	○	○	○	○	
	Reducers	●	●	●	●	●	○	○	○	○	○	○	○	○	○	○	○	○	

● Demonstrated effectiveness
 ○ Potential effectiveness
 ○ No effectiveness
 × Potential adverse impacts to process or environment

* Do not use this matrix table alone. Please refer to the cited appendices for guidance

Table 3 Waste Technology Matrix: Sludges.

Contaminant		Technology													
		A.1-1	A.2-1	A.3-1	A.4-1	A.5-1	A.6-1	B.1-1	B.2-1	B.5-1	B.8-1	B.9-1	B.10-1	C.1-1	C.2-1
Organic	Table	Fluidized bed incineration	Rotary kiln incineration	Infrared thermal treatment	Wet air oxidation	Pyrolysis-incineration	Vitrification	Chemical extraction	In situ chemical treatment	Glycolate dechlorination	Stabilization/solidification	Chemical reduction oxidation	In situ vitrification	Biodegradation	In situ biodegradation
	Halogenated volatiles	●	●	●	●	●	●	●	○	●	●	●	●	●	●
	Halogenated semivolatiles	●	●	●	●	●	●	●	○	●	●	●	●	●	●
	Nonhalogenated volatiles	●	●	●	●	●	●	●	○	○	●	●	●	●	●
	Nonhalogenated semivolatiles	●	●	●	●	●	●	●	○	○	●	●	●	●	●
	PCBs	●	●	●	●	●	●	●	○	○	●	●	●	●	●
	Pesticides	●	●	●	●	●	●	●	○	○	●	●	●	●	●
	Organic cyanide	●	●	●	●	●	●	●	○	○	●	●	●	●	●
	Organic corrosives	●	●	●	●	●	●	●	○	○	○	○	○	○	○
	Inorganic	Volatile metals	×	×	×	○	○	×	○	○	○	○	●	○	×
Nonvolatile metals		○	○	○	○	○	○	○	○	○	○	●	○	×	×
Asbestos		○	○	○	○	○	○	○	○	○	○	○	○	○	○
Radioactive materials		○	○	○	○	○	○	○	○	○	○	○	○	×	×
Inorganic corrosives		○	○	○	○	○	○	○	○	○	○	○	○	×	×
Inorganic cyanides		○	○	○	○	○	○	○	○	○	○	○	○	×	×
Reactive	Oxidizers	○	○	○	○	○	○	×	○	○	○	○	○	×	×
	Reducers	○	○	○	○	○	○	×	○	○	○	○	○	×	×

- Demonstrated effectiveness
- ◐ Potential effectiveness
- No effectiveness
- ×

* Do not use this matrix table alone. Please refer to the cited appendices for guidance.

require bench- and/or pilot-scale testing. Indication of potential effectiveness of a technology to a waste group does not signify applicability to all chemical compounds within the waste group.

3. No effectiveness - (Symbol 0). The technology is not expected to remove or destroy the contaminant to a significant degree, but the contaminant does not interfere with or adversely impact the process (e.g., vacuum extraction, used to remove volatile organics, neither treats nor is affected by metals in the soil).
4. Adverse impacts - (Symbol X). The contaminant is likely to interfere with or adversely impact the environment or the safety, effectiveness, or reliability of the treatment process (e.g., the adverse impact of high concentrations of available biotoxic metals on in situ biodegradation for soils). Note that such adverse impacts may only occur above some threshold concentration, and pretreatment may alleviate the adverse impact. Refer to the technology summaries and tables for the specific nature of the adverse impact.

2.3 Technology Restriction Tables

Following the identification of potentially applicable treatment technologies on Tables 2 and 3, the user should refer to the appropriate technology restriction tables (provided in the appendices) to identify potentially restrictive waste and/or matrix (i.e., soil or sludge) characteristics that can interfere with process feasibility and/or operation. To determine whether these restrictive characteristics apply to the specific waste to be treated, additional data on the waste or soil may be required. These general data collection requirements are given in the technology restriction tables provided in the appendices.

Where available, data on restrictive characteristics have been included in the technology restriction tables to assist the user in evaluating potential technologies. The data have been extracted from sources addressing the technology generically and from sources, including vendors, that describe a specific treatment system. The data should be used only as a guideline or estimate for applicability purposes; they are not transferable to every application and are not intended as a substitute for case-specific assessments by qualified professionals.

A preliminary screening of remedial alternatives, detailed characterization of the site, and analysis of remedial alternatives are the next steps in the site remediation process. This guide is designed to make these steps more efficient by focusing on potentially applicable technologies and the data collection requirements needed to evaluate them. This guide facilitates identification of each technology based on the characteristics of the site and waste. Consequently, this guide is not intended to replicate the site and alternatives evaluation, but is intended only to help identify those technologies worthy of further evaluation.

The technology restriction tables can be used at several stages of the remedial investigation or site-sampling process to support characterization of the technical feasibility of a treatment method. However, this guide is designed only to assist in screening alternative technologies and in identifying the data collection requirements needed to evaluate technical feasibility. The potential technologies thus identified must be further evaluated by using the references provided, contacting technology experts (including vendors), performing bench- and/or pilot-scale testing as necessary, and considering site-specific circumstances on a case-by-case basis. Treatability testing may be required to determine the

applicability of some technologies. This is particularly true for the innovative, undemonstrated technologies (e.g., soil washing, soil flushing, and in situ biodegradation) and the technologies whose effectiveness is highly dependent on the characteristics of the waste (e.g., stabilization).

2.4 Pretreatment and Residuals Management Tables

As discussed in previous sections, the technology restriction tables identify characteristics of wastes and sites that may affect the feasibility of using a technology. The effects of many of these potentially restrictive characteristics can be eliminated or reduced through pretreatment of the waste. In many cases, wastes will require pretreatment before they can be treated by any method. In addition, wastes normally will need to be excavated and/or transported to the treatment unit. Therefore, for the purposes of this guidance, waste materials handling is included as part of pretreatment.

Pretreatment, materials handling, or processing requirements for a waste are often not recognized until the advanced stages of pilot testing or implementation of a treatment system. This may cause significant delays and escalate costs while the waste or equipment is modified. For example, vendors of soil-washing and mobile incineration systems often have cited materials handling and processing as the key problems at a site rather than the technical performance of the system.

This guide contains two pretreatment/materials handling tables: one for sludges (Table 4) and one for soils (Table 5). These tables provide general examples of how some common restrictive characteristics can be pretreated. The tables also present some common materials handling techniques. Whenever possible, an attempt has been made to alert the user to those restrictive characteristics identified in the technology restriction tables that may possibly be handled through pretreatment by referencing the appropriate pretreatment/materials handling table.

These tables are not designed to identify every possible pretreatment/materials handling technique for each restrictive characteristic. Instead, they are designed to be used as a starting point and to convey to the user that the presence of restrictive characteristics should not necessarily eliminate a technology from consideration.

As a final table to facilitate selection of potential treatment technologies, Table 6 presents a listing of the probable residual streams produced by treatment. Ways of managing the residuals, such as stabilization of incinerator ashes or biological treatment of leachates with trace quantities of organics, are also cited.

Table 4 Pretreatment/Materials Handling Table: Sludges.

<i>Problem</i>	<i>Solution</i>	<i>Comments</i>
<i>Material transport and excavation</i>	<i>Dragline</i>	<i>Crane-operated excavator bucket to dredge or scrape sludge from lagoons, ponds, or pits.</i>
	<i>Backhoe, excavator</i>	<i>Useful for subsurface excavation or at the original ground level.</i>
	<i>Mudcat</i>	<i>Bulldozer or loader much like a crawler capable of moving through sludge.</i>
	<i>Positive displacement pump (e.g., cement pump)</i>	<i>Pump that can handle high-density sludges containing abrasives such as sand and gravel.</i>
	<i>Moyno pump</i>	<i>Progressing cavity pump that can pump high-viscosity sludges.</i>
<i>Excessive water content</i>	<i>Evaporator</i>	<i>Excess water can be evaporated from sludge. The Carver-Greenfield process is a potentially applicable technology. The sludge is mixed with oil to form a slurry, and the moisture is evaporated through a multiple-effect evaporator.</i>
	<i>Filter press</i>	<i>Sludge is pumped into cavities formed by a series of plates covered by a filter cloth. The liquid seeps through the filter cloth, and the sludge solids remain.</i>
	<i>Belt filter</i>	<i>Sludge drops onto a perforated belt, where gravity drainage takes place. The thickened sludge is pressed between a series of rollers to produce a dry cake.</i>
	<i>Vacuum filter</i>	<i>Sludge is fed onto a rotating perforated drum with an internal vacuum, which extracts liquid phase.</i>
	<i>Centrifuge (solid bowl)</i>	<i>Sludge feeds through a central pipe that sprays it into a rotating bowl. Centrate escapes out the large end of the bowl, and the solids are removed from the tapered end of the bowl by means of a screw conveyer.</i>
	<i>Drying</i>	<i>Rotary drying, flash drying, sand bed.</i>
	<i>Gravity thickening</i>	<i>Slurry enters thickener and settles into circular tank. The sludge thickens and compacts at the bottom of the tank, and the sludge blanket remains to help further concentration.</i>
	<i>Chemical addition</i>	<i>Compounds may be added to physically or chemically bind water</i>

Table 4 Pretreatment/Materials Handling Table: Sludges (continued).

<i>Problem</i>	<i>Solution</i>	<i>Comments</i>
<i>Excessive sludge viscosity</i>	<i>Slurry</i>	<i>Addition of water or solvent; addition of dispersants.</i>
<i>Extreme pH</i>	<i>Neutralization</i>	<i>Lime, an alkaline material, is widely used for neutralizing acid wastes; sulfuric acid is used to neutralize alkaline wastes</i>
<i>Oversized material. removal disaggregation, sorting</i>	<i>See Table 5 (Soils)</i>	

Table 5 Pretreatment/Materials Handling Table: Soils.

<i>Problem</i>	<i>Solution</i>	<i>Comments</i>
<i>Material transport and excavation</i>	<i>Dragline</i>	<i>Crane-operated excavator bucket to dredge or scrape soil to depths and farther reaches..</i>
	<i>Backhoe</i>	<i>Useful for subsurface excavation or at the original ground level.</i>
	<i>Heavy earthmoving equipment</i>	<i>Includes bulldozers, excavators, and dump trucks for excavation and transport.</i>
	<i>Conveyer</i>	<i>May be useful for large-volume transport or feed to treatment unit.</i>
<i>Oversized material removal, disaggregation, sorting</i>	<i>Vibrating screen</i>	<i>Vibrates for screening of fine particles from dry materials. There is a large capacity per area of screen, and high efficiency. Can be clogged by very wet material.</i>
	<i>Static screen</i>	<i>A wedge bar screen consists of parallel bars that are frame-mounted. A slurry flows down through the feed inlet and flows tangentially down the surface of the screen. The curved surfaces of the screen and the velocity of the slurry provide a centrifugal force that separates small particles.</i>
	<i>Grizzlies</i>	<i>Parallel bars that are frame-mounted at an angle to promote materials flow and separation. Grizzlies are used to remove a small amount of oversized material from predominantly fine soil.</i>
	<i>Hammer mill</i>	<i>Used to reduce particle size of softer materials.</i>

Table 5 Pretreatment/Materials Handling Table: Soils (continued).

<i>Problem</i>	<i>Solution</i>	<i>Comments</i>
<i>Oversized material removal, disaggregation, sorting (cont.)</i>	<i>Impact crusher</i>	<i>Breaks up feed particles by impact with rotating hammers or bars. Impact crushing works best with material that has several planes of weakness, such as impurities or cracks.</i>
	<i>Shredder</i>	<i>Reduces size of waste material. Shredders are available to handle most materials, including tires, metal, scrap, wood, and concrete.</i>
	<i>Tumbling mill</i>	<i>Reduces size of rock and other materials using a rotating drum filled with balls, rod, tubes, or pebbles.</i>
	<i>Cyclone</i>	<i>Separates different sized particles by centrifugation and gravity.</i>
<i>Fugitive emissions</i>	<i>Dust suppressant</i>	<i>Natural (e.g., water) or synthetic materials that strengthen bonds between soil particles.</i>
	<i>Negative pressure air system</i>	<i>Vacuum system that may be used to collect vapors and/or dust particles and prevent release into atmosphere.</i>
	<i>Foam</i>	<i>Applied to soil surface to control volatile emissions and dust during excavation</i>
	<i>Covered shelter</i>	<i>Temporary shelter with structurally or air supported cover to restrict emissions to enclosed volume.</i>
<i>Dewatering</i>	<i>Belt filter press, centrifuge</i>	<i>Useful for dewatering of very wet soils (lagoon sediments, wetlands).</i>
	<i>Rotating dryer</i>	<i>Additional drying may permit higher feed rates for thermal treatment systems.</i>

Table 6 Residuals Management.

<i>Residual</i>	<i>Technology Generating Residual</i>	<i>Contaminants</i>	<i>Potential Management</i>
<i>Treated soil or ash</i>	<i>Fluidized bed incineration, infrared thermal treatment, rotary kiln incineration</i>	<i>Metals</i>	<i>Stabilization/solidification, vitrification</i>
<i>Treated soil</i>	<i>Low-temperature thermal stripping</i>	<i>Metals, nonvolatile organics</i>	<i>Stabilization/solidification, vitrification</i>
<i>Afterburner ash</i>	<i>Low-temperature thermal stripping</i>	<i>Volatile metals</i>	<i>Stabilization/solidification, vitrification</i>
<i>Solids (ash)</i>	<i>Wet air oxidation</i>	<i>Metal oxides, insoluble salts</i>	<i>Mechanical dewatering, stabilization/solidification</i>
<i>Glass residue</i>	<i>Vitrification</i>	<i>Nonvolatile metals at the operating temperature</i>	<i>Disposal</i>
<i>Solids</i>	<i>Chemical extraction - basic extractive sludge treatment</i>	<i>Metals, trace organics</i>	<i>Stabilization/solidification, vitrification</i>
<i>Spent activated carbon</i>	<i>Low-temperature thermal stripping, air pollution control device, wastewater treatment</i>	<i>Volatile organics</i>	<i>Incineration, thermal regeneration, wet air oxidation, steam stripping with water treatment, biodegradation</i>
<i>Fly ash</i>	<i>Electrostatic precipitator, baghouse, cyclone</i>	<i>Volatile metals</i>	<i>Stabilization/solidification, recycle to primary thermal unit, reuse of ash</i>
<i>Leachate</i>	<i>Biodegradation, stabilization/solidification</i>	<i>Trace metals</i>	<i>Chemical precipitation Stabilization/solidification</i>
		<i>Trace organics</i>	<i>Biological treatment or carbon adsorption, photooxidation, chemical oxidation</i>
<i>Aqueous effluent</i>	<i>Chemical extraction, soil washing</i>	<i>Trace organics</i>	<i>Biological treatment or carbon adsorption</i>
	<i>Wet air oxidation</i>	<i>Carboxylic acids and other carbonyl group compounds; low molecular weight organics, such as acetaldehyde, acetone, methanol</i>	<i>Biological treatment or carbon adsorption, photooxidation, chemical oxidation</i>

Table 6 Residuals Management (continued).

<i>Residual</i>	<i>Technology Generating Residual</i>	<i>Contaminants</i>	<i>Potential Management</i>
<i>Water/ reagent mix</i>	<i>Glycolate dechlorination</i>	<i>Organics</i>	<i>Distillation followed by incineration</i>
<i>Water/ flushing agent mix</i>	<i>Soil washing/ soil flushing</i>	<i>Organics</i>	<i>Distillation, carbon adsorption, biological treatment, chemical oxidation, photochemical oxidation</i>
		<i>Metals</i>	<i>Chemical precipitation</i>
		<i>Cyanides</i>	<i>Chemical oxidation, wet air oxidation, electrolytic oxidation, photochemical oxidation</i>
<i>Organic effluent</i>	<i>Solvent extraction</i>	<i>Organics (non- PCBs)</i>	<i>Recycle or reuse as fuel</i>
		<i>Organics mixed with PCBs</i>	<i>Incineration</i>
<i>Scrubber water</i>	<i>Incineration (fluidized bed incineration, rotary kiln incineration, vitrification unit, infrared thermal treatment), off-gas collection and treatment</i>	<i>Caustic, high chloride content, volatile metals, organics, metal particulates, and inorganic particulates</i>	<i>Neutralization, chemical precipitation, reverse osmosis, settling ponds, evaporation ponds, filtration, and gas phase incineration of organics, chemical oxidation, photochemical oxidation</i>
<i>Off-gas</i>	<i>In situ vitrification</i>	<i>Trace levels of combustion products, volatile metals, and/or volatile organics</i>	<i>Gas scrubber, activated carbon adsorption</i>
	<i>Stabilization/ solidification</i>	<i>Ammonia, volatile organics</i>	<i>Gas scrubber, carbon adsorption</i>
	<i>Wet air oxidation</i>	<i>Low molecular weight compounds, such as acetaldehyde, acetone, acetic acid, methanol</i>	<i>Gas scrubber, carbon adsorption, fume incineration, biological treatment</i>

2.5 Examples for Using This Guide

Provided below are two examples that illustrate how to use this guide. The first example is for soils or sludges containing a single waste group (as defined in Table 1); the second example illustrates the use of the guide for soils and sludges containing multiple waste groups.

2.5.1 Example for a Single Waste Group

The steps involved in using this guide for contaminated soils or sludges containing a single waste group are as follows:

1. Perform preliminary waste characterization.
 - Identify the waste matrix (soil or sludge)
 - Identify contaminants of concern.
 - Classify contaminants into waste groups using Table 1; if waste contains more than one waste group, use procedure given in Section 2.5.2.
2. Consult appropriate waste/technology table (Tables 2 and 3).
 - Generate a list of potential technologies.
3. Evaluate technology restriction tables, technology descriptions, and pretreatment/materials handling tables for identified technologies.
 - Refine list of potential technologies.
 - Identify data collection requirements.
4. Contact EPA experts and/or vendors for further information (if necessary).
5. Finalize list of potential technologies and data collection requirements needed for further evaluation.

As outlined above, the initial waste characterization step identifies the waste matrix and waste group (contaminant). The user should then consult the appropriate waste/technology table, Table 2 for soils or Table 3 for sludges. The next step is to find the contaminant or waste group in the left margin, read across the table, and list those technologies identified as having a demonstrated or potential effectiveness. Next, the technology restriction table for each potential technology should be evaluated to identify possible restrictive waste characteristics, process limitations, and data collection requirements needed for further evaluation. A number of technology restriction tables direct the user to the pretreatment/materials handling tables, Table 4 for sludges and Table 5 for soils. These tables contain common materials handling, processing, and pretreatment options that may eliminate or reduce restrictive waste characteristics.

2.5.2 Example for Multiple Waste Groups

The steps involved in using this guide for contaminated soils or sludges containing multiple waste groups are as follows:

1. Perform waste characterization.
 - Identify waste matrix (soil or sludge).
 - Identify contaminants of concern.
 - Classify contaminants into waste groups using Table 1.

2. Consult appropriate waste/technology table (Table 2 or 3) for each waste group.
 - Generate a list of potential technologies for each waste group.
3. Evaluate technology restriction tables, technology descriptions, and pretreatment/materials handling tables for each potential technology and waste group.
 - Identify technologies (if any) that alone are capable of treating all waste groups identified.
 - Develop potential treatment trains.
 - Identify data collection requirements.
4. Contact EPA experts and/or vendors for further information (if necessary).
5. Finalize list of technologies capable of treating all waste groups identified, list of potential treatment trains, and data collection requirements needed for further evaluation.

As shown above, this guide can also be used to evaluate the treatability of waste soils or sludges containing more than one type of contaminant or waste group. When evaluating wastes with multiple waste groups, the first step is to evaluate each waste group independently, as described above.

The next step is to compare the list of technologies identified for the waste groups. The ideal solution would be to find one or more technologies that have effectiveness (demonstrated or potential) on all of the waste groups of concern. If such a technology can be identified, its technology restriction table should be carefully evaluated against each waste group for possible restrictive characteristics and data collection requirements.

If a single technology with demonstrated or potential effectiveness cannot be identified, combinations of technologies or treatment trains that can successfully treat the waste should be identified. A treatment train is composed of two or more technologies used in series. Each technology is included to remove or destroy a certain waste group or contaminant; therefore, each technology needs to be effective only on its target waste group. Technologies may be effective on one waste group but are adversely impacted by another present in the waste. These technologies can be used as part of a treatment train provided the interfering waste group is treated prior to being processed by the technology. Each technology restriction table should, therefore, be thoroughly evaluated against each waste group to identify contaminants that must be treated prior to application of particular technologies. This step allows the user to develop the order of the technologies within a potential treatment train.

By reviewing the waste/technology tables, technology restriction tables, and pretreatment tables, the user will be able to identify possible treatment trains, the restrictive waste characteristics that can affect the trains, the data collection requirements necessary to identify potential problems, and the pretreatment needed to resolve various waste-handling problems. This information, along with the referenced documentation and EPA and vendor contacts, will make it possible for the user to initiate advanced planning for in-depth engineering studies and/or bench-scale testing of potential treatment technologies.

Section 3

Application of this Guide to a Hypothetical Waste

This section illustrates the use of this guide by describing, step-by-step, a technology screening for a hypothetical waste. (See Figure 2.) The first step is to perform a preliminary waste characterization as described in Section 2.1. The waste characterization step involves identifying the physical/chemical form or matrix of the waste (i.e., soil or sludge) and contaminants (usually based on existing data). For this example, the waste characterized is a soil contaminated with trichloroethylene (TCE) and lead. These constituents were chosen for this example because they represent commonly occurring waste groups.

The two waste groups are initially screened separately. On Table 1 (Waste Group Examples), TCE is classified as a halogenated volatile organic and lead is classified as a volatile metal.

Table 2 identifies the following technologies as having demonstrated effectiveness or potential effectiveness on soils contaminated with halogenated volatiles such as TCE:

- Rotary kiln incineration (demonstrated);
- Fluidized bed incineration;
- Infrared thermal treatment;
- Vitrification;
- Soil washing;
- Glycolate dechlorination;
- Low temperature thermal stripping;
- Chemical extraction;
- In situ vacuum and steam extraction;
- In situ vitrification;
- In situ soil flushing; and
- In situ biodegradation.

According to Table 2, three technologies have demonstrated effectiveness or potential effectiveness on soils contaminated with volatile metals such as lead:

- Stabilization/solidification (demonstrated);
- Soil washing; and
- In situ vitrification.

Comparison of the two lists reveals two technologies that could potentially treat both waste groups in a single step. Soil washing and in situ vitrification are potentially effective on both waste groups.

The next step is to consult the technology summaries for both technologies to determine restrictive waste characteristics.

Soil Washing (Table B.3-1) - The table indicates that the formulation of a suitable washing fluid is difficult for wastes containing mixtures of organics (i.e., TCE) and metals (i.e., lead). The effectiveness of the technology also appears highly dependent on the characteristics of the soil.

Figure 2. Screening methodology flowchart for a hypothetical waste.

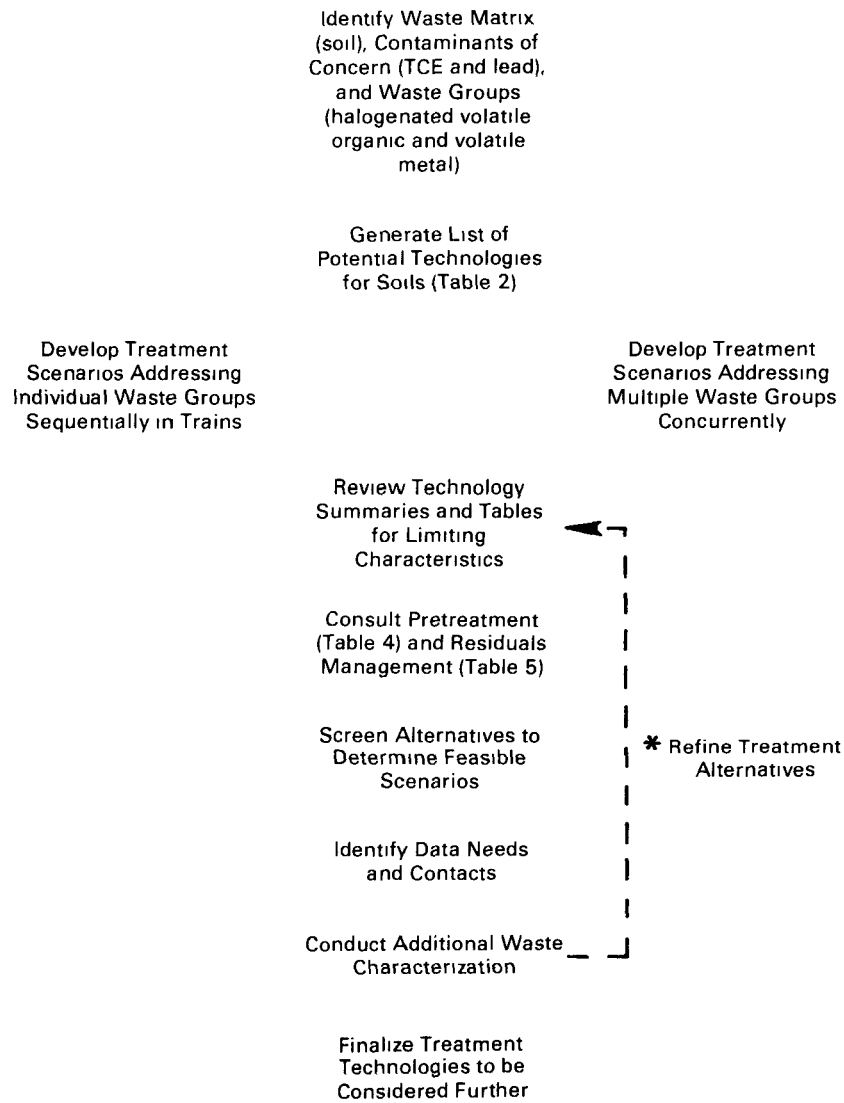

This technology may not be suitable for this waste; if the lead concentration is such that extensive quantities of washing fluid would be required or if the soil consists of a high percentage of clay, then the soil/metal complex may be difficult to manage effectively.

In Situ Vitrification (Table B.10-1) - The table indicates that the capacity of the off-gas treatment system to process combustion gas limits the concentration of combustible liquids and solids that can be treated by the melt during an established period of time. The allowable concentration is also depth related. Mapping the site and bench-scale testing are vital to determine the technology's feasibility at a particular site. Lead is not identified as a restrictive characteristic. The technology summary indicates that the TCE will be destroyed while the lead is solidified in the resulting glass-like mass.

From the review of the technology restriction tables, in situ vitrification shows promise as a single technology that can effectively treat soil contaminated with both TCE and lead. Extensive site mapping and feasibility testing are required to determine if in situ vitrification can be implemented at the particular site. The technology description indicates that an off-gas will be generated by the process, requiring off-gas collection with a hood and treatment. The residuals management table (Table 6) indicates that the off-gas will contain combustion products, traces of TCE (from volatilization, during startup, of organics that are located close to the surface), and traces of volatile metals (including lead) that may be present on-site. A gas scrubber is necessary to treat the off-gas, as recommended by the table.

The treatment of wastes containing organics and metals would be more difficult with soil washing than with in situ vitrification. However, in situ vitrification is not demonstrated at commercial scale on CERCLA waste. Furthermore, no commercial, full-scale units are available at this time.

Since the feasibility of in situ vitrification is site specific and therefore may not apply to the site in question and since soil washing will not likely treat the contaminated soil effectively, the next step is to identify and evaluate each possible multistep treatment process or treatment train. Obviously, there are many possibilities to cover; only a few possible treatment trains will be investigated here to illustrate the screening process.

Low Temperature Thermal Stripping Followed by Stabilization/Solidification - One possible TCE-lead treatment train is low temperature thermal stripping of TCE followed by stabilization/solidification of the lead compounds. Table 2 indicates that low temperature thermal stripping is potentially effective on TCE but has little effect on lead. In addition, Table B.6-1, the technology restriction table for low temperature thermal stripping, indicates that the technology is not effective on metals. This restrictive characteristic would preclude the use of this technology for removing both contaminants; however, the low temperature thermal stripping segment of the train is included only for TCE removal. No restrictive characteristics are listed in Table B.6-1 for volatile organics (TCE), although the technology's effectiveness appears highly dependent on soil characteristics. Therefore, further evaluation of this technology should concentrate on defining site-specific soil characteristics. Table 6 presents potential management options for spent carbon adsorption units that may be used in the process to remove the volatile organics from the off-gas. Thermal regeneration, incineration, and wet air oxidation are options that must be considered as part of the treatment train for treating the spent carbon.

The second segment of the treatment train would involve stabilization/solidification of the lead. The majority (if not all) of the volatile organic, TCE in this example, would have been removed by the low temperature thermal treatment step of the treatment train. Furthermore, this segment of the treatment train is targeted only at lead treatment; therefore, its effectiveness on TCE is not important if the low temperature thermal stripping has effectively removed the TCE. If the TCE has not been effectively treated in the thermal treatment step, however, it could interfere with the stabilization/solidification process.

Based upon the information contained in this guide, a low temperature thermal treatment/stabilization treatment train would appear to be potentially feasible and warrant further investigation as part of an engineering study.

Chemical Extraction Followed by Stabilization/Solidification - Another possible TCE-lead treatment train is chemical extraction to extract the TCE, followed by stabilization/solidification of the lead-containing solid residue. Table 2 shows that chemical extraction is potentially effective on TCE but has no effect on lead. The presence of elevated levels of volatiles, such as TCE, is identified under Table B.1-1 as impacting the extraction process. However, Table B.1-1 further explains that an additional separation step, such as distillation, will remove the volatiles from the process solvent, thus eliminating any problems. The technology description (B.1) explains that lead, insolubilized by a standard neutralization/precipitation pretreatment step, will remain with the solids following the chemical extraction step.

Upon examination of Table B.1-1, listed technology restrictions that affect the process can be addressed by using pretreatment methods such as pulverizing to reduce particle size, slurring to allow the soil to be pumped, adjusting pH, and selecting the appropriate solvent-to-waste ratio. Therefore, further evaluation of this technology should concentrate on defining site-specific soil characteristics to determine the necessary pretreatment steps. Also, pretreatment methods or materials handling procedures may cause fugitive emissions of TCE and must be controlled.

The second segment of the treatment train would involve stabilization/solidification of the lead. As explained above, although TCE is not effectively immobilized by the process, it will already have been removed by chemical extraction. If extraction has not effectively removed the TCE, however, it could interfere with the stabilization/solidification process. The lead should be effectively immobilized by the stabilization step.

The TCE residue extracted from the soil may potentially be reused as a fuel or in some other process if analysis shows the organic stream to be of sufficient purity and quantity. The potentially feasible chemical extraction/stabilization treatment train may be an attractive option warranting further investigation because of its ability to produce a reusable organic stream.

Rotary Kiln Incineration Followed by Stabilization/Solidification - Rotary kiln incineration followed by stabilization/solidification of the resulting ash and/or treatment of scrubber water is another possible treatment train. Table 2 indicates that rotary kiln incineration has been demonstrated on soils contaminated with halogenated volatiles, such as TCE. Table A.2-1 does not mention lead as affecting the rotary kiln treatment process; however, lead air emissions may restrict the use of incineration. The presence of restrictive characteristics identified in Table A.2-1 must be established by determining site-specific soil characteristics to further evaluate the usefulness of this technology at a particular site.

The treated soil or residual ash will no longer contain TCE but will still contain lead. The residual ash will need to be treated in the stabilization/solidification stage of the treatment train. Considerations for stabilization/solidification were discussed in the previous examples.

The need for residuals management for this treatment train is identified in both the technology restriction tables and Table 6. The rotary kiln will generate a scrubber water from its off-gas cleaning process that will be a caustic, high chloride content waste. Since volatile metals are in the influent to the kiln, they may appear in the scrubber water and in air emissions if the scrubber is not sufficiently effective. The residuals management table indicates the need for neutralization (and possibly precipitation if some lead is carried over in the off-gas and collected in the scrubber) before the scrubber water can be discharged. A rotary kiln/stabilization treatment train with appropriate residuals management would appear to be potentially feasible and warrant further investigation as part of an engineering study.

APPENDICES

Appendix A

Thermal Treatment Technologies

Introduction

Thermal treatment is a term associated with the use of high temperatures as the principal means of destroying or detoxifying hazardous wastes. There are several thermal processing methods; some are well-developed and proven, and others are in the development stage. The thermal processing modes described herein are:

- Fluidized bed incineration for soils and sludges;
- Rotary kiln incineration for soils and sludges;
- Infrared thermal treatment for soils and sludges;
- Wet air oxidation treatment for sludges;
- Pyrolytic incineration for soils and sludges; and
- Vitrification for soils and sludges.

More specific information on the applications of each thermal process is given in the sections that follow. Low temperature thermal volatilization (i.e., stripping) is discussed under physical/chemical treatment in Section B.6.

The advantages of thermal treatment include:

- Volume reduction;
- Detoxification;
- Energy recovery; and
- Materials recovery.

Thermal treatment offers essentially complete destruction of the original organic waste. The destruction and removal efficiency (DRE) achieved for waste streams incinerated in properly operated thermal processes often exceeds the 99.99 percent requirement for hazardous wastes. Hydrogen chloride (HCl) emissions are also easily controlled. Furthermore, available air pollution control technologies can effectively address the potential for particulate emissions. This appendix contains information on individual thermal treatment technologies. Table A-1 summarizes waste characteristics that impact thermal treatment technologies in general. For each specific thermal technology, a technology description is provided, followed by an illustration of the process and a technology restriction table. Each technology restriction table includes a listing of the characteristics impacting the feasibility of the process, reasons for restriction, data collection requirements, and references. The numbers in the "Reference" column are correlated with the list of references included at the end of this appendix.

Table A-1 Technology Summary.

Waste Type: Soils and Sludges
Technology: High-Temperature Thermal Treatment - General*

<i>Characteristics Impacting Process Feasibility</i>	<i>Reason for Potential Impact</i>	<i>Data Collection Requirements</i>	<i>Ref.</i>
<i>High moisture content</i>	<i>Moisture content affects handling and feeding and has major impact on process energy requirement.</i>	<i>Analysis for percent moisture</i>	<i>1</i>
<i>Elevated levels of halogenated organic compounds</i>	<i>Halogens form HCl, HBr, or HF when thermally treated; acid gases may attack refractory material and/or impact air emissions.</i>	<i>Quantitative analysis for organic Cl, Br, and F</i>	<i>2,3,4</i>
<i>Presence of PCBs, dioxins</i>	<i>PCBs and dioxins are required to be incinerated at higher temperatures and long residence times. Thermal systems may require special permits for incineration of these wastes.</i>	<i>Analysis for priority pollutant</i>	<i>2,3</i>
<i>Presence of metals</i>	<i>Metals (either pure or as oxides, hydroxides, or salts) that volatilize below 2,000°F (e.g., As, Hg, Pb, Sn,) may vaporize during incineration. These emissions are difficult to remove using conventional air pollution control equipment. Furthermore, elements cannot be broken down to nonhazardous substances by any treatment method. Therefore, thermal treatment is not useful for soils with heavy metals as the primary contaminant. Additionally, an element such as trivalent chromium (Cr⁺³) can be oxidized to a more toxic valence state, hexavalent chromium (Cr⁺⁶), in combustion systems with oxidizing atmospheres.</i>	<i>Analysis for heavy metals</i>	<i>2,3,4</i>
<i>Elevated levels of organic phosphorus compounds</i>	<i>During combustion processes, organic phosphorus compounds may form phosphoric acid anhydride (P₂O₅), which contributes to refractory attack and slagging problems.</i>	<i>Analysis for phosphorus</i>	<i>2,3</i>

* Applicable to fluidized bed, infrared, rotary kiln, wet air oxidation, and pyrolytic as well as vitrification processes.

A.1 Fluidized Bed Incineration

Technology Description

Fluidized bed incinerators are used to incinerate halogenated and nonhalogenated solids, sludges, slurries, and liquids in a controlled atmosphere with surplus oxygen levels. These systems are also used to destroy PCBs and phenolic wastes and to thermally decontaminate soils.

The fluidized bed incinerator consists of a refractory-lined vessel containing a bed of inert, granular, sand-like material (sized crushed refractory). Solids, sludges, and liquids can be injected directly into the bed or at its surface. If contaminated soil is being processed, the soil mass acts as the bed material. In one design (Waste-Tech) the decontaminated soils and heavy noncombustible inert material are continually withdrawn from the bottom of the vessel. In operation, combustion air is forced upward through the bed, which fluidizes the material at a minimum critical velocity. The heating value of the wastes plus minimal auxiliary fuel maintains a desired combustion temperature in the vessel. The heat of combustion is transferred back into the bed, and the agitated mixture of waste, fuel, and hot bed material in the presence of fluidizing air provides a combustion environment that resists fluctuations in temperature and retention time due to moisture, ash, or Btu content of the waste.

A secondary reaction chamber is employed to permit adequate retention time (2 seconds plus) for combustion of volatiles. Combustion gases are drawn out of the end of the secondary reaction chamber and treated for removal of acid gas and particulate constituents. Process residuals are decontaminated ash, treated combustion gases, and possibly wet scrubber water.

Fluidized beds can be operated at lower temperatures than other incinerators because of the high mixing energies aiding the combustion process. This mixing offers the highest thermal efficiency while minimizing auxiliary fuel requirements and volatile metals emissions. Fluidized bed systems may make use of in-bed limestone addition for acid gas capture, which removes the requirement for wet scrubbers and blowdown water treatment.

A variation of fluidized bed incinerator, the Circulating Bed Combustor (CBC), uses higher air velocity and circulating solids to create a larger and highly turbulent combustion zone for the efficient destruction of toxic chemicals and the retention of resultant acid vapors. Solids, liquids, or sludges are burned along the height of the combustion section. Dry limestone, added to the feed, reacts in the combustion zone and captures acid gases without using wet scrubbers. The high turbulence, staged combustion, and long residence time in circulating bed combustors allow incineration of the waste at lower temperatures (1500-1600°F), thus eliminating ash agglomeration and reducing nitrous oxide (NO_x) emissions. The entrained solids are separated from off-gases by an integral cyclone and recycled to the combustor through a nonmechanical seal. The flue gases are cooled in an off-gas cooler by the heating of water, steam, or combustion air. Any remaining particulates in the cooled off-gas are separated in a baghouse filter, and the clean off-gas stream is vented to the atmosphere.

Status: This technology is used widely in the U.S. paper industry and on wastes throughout Europe. A full-scale fluidized bed system has successfully completed its Part B Permit trial burn on RCRA and other toxic wastes. Ogden Environmental Services has constructed at least one commercial, mobile unit, and others are planned.

Figure A.1-1 is a diagram of the fluidized bed incineration process, Figure A.1-2 is a diagram of a circulating bed combustor, and Table A.1-1 is a technology restriction table.

EPA Contacts:

Donald Oberacker, (513) 569-7341, FTS 684-7341
U.S. Environmental Protection Agency
Risk Reduction Engineering Laboratory
Cincinnati, OH 45268

Joseph McSorley, (919) 541-2920, FTS 629-2920
U.S. Environmental Protection Agency
Air and Energy Engineering Research Laboratory
Research Triangle Park, NC 27711

Vendors:

Harold Diot, (619) 455-2383
Ogden Environmental Services, Inc. (CBC)
10955 John Jay Hopkins Dr.
San Diego, CA 92121

Wayne L. Shipman, P.E., (303) 279-9712
Waste-Tech Services, Inc.
18400 West 10th Avenue
Golden, CO 80401

Minesh Kinkhabwala, (201) 922-2323
C-E Environmental
Combustion Engineering, Inc.
7 Becker Farm Rd.
Roseland, NJ 07068

Figure A.1-1. Fluidized bed incineration.

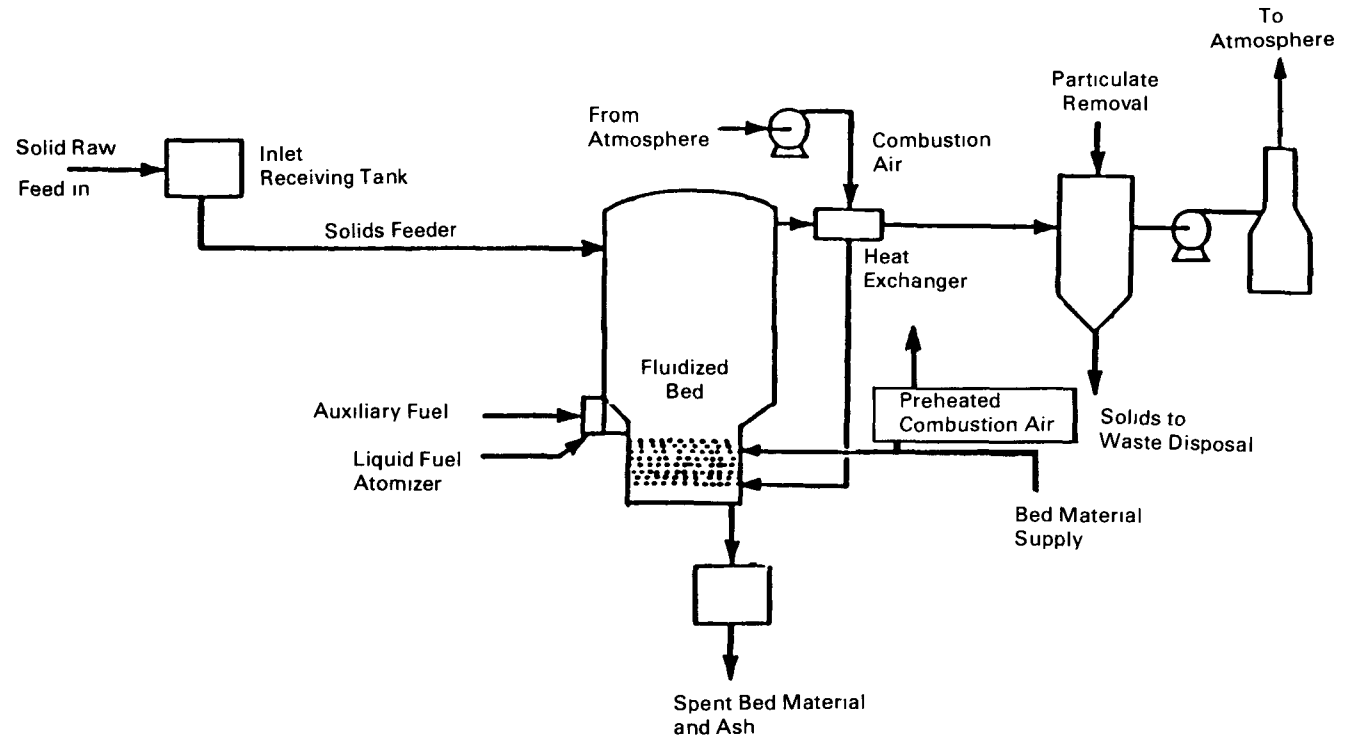

Source: Figure 2.2, EPA/540/2-86/003(f)

Figure A.1-2 Circulating bed combustor.

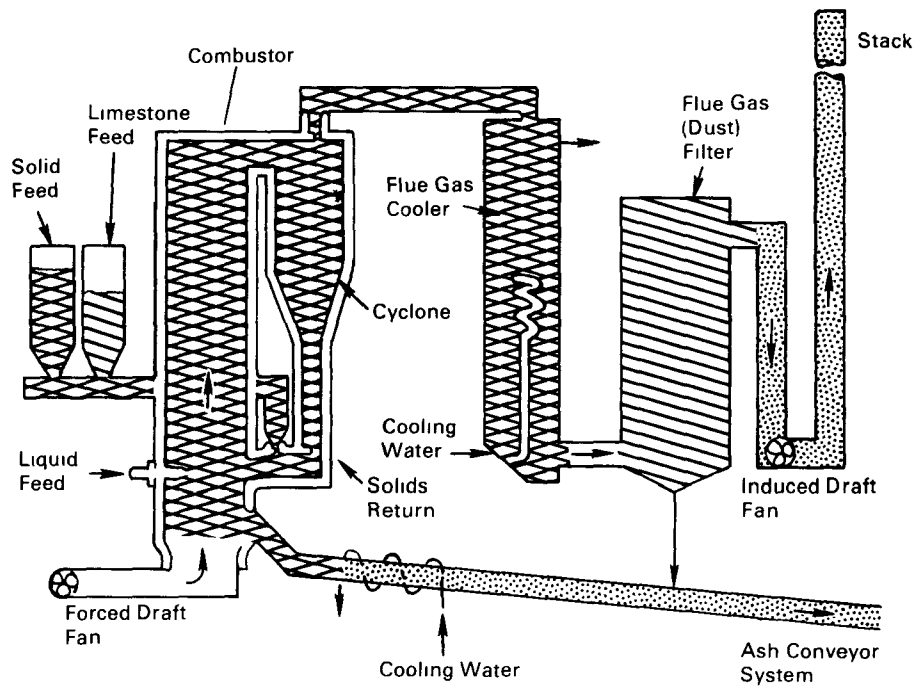

Source: Ogden Environmental Services

Table A.1-1 Technology Summary.

Waste Type: Soils and Sludges
Technology: Fluidized Bed Incineration*

<i>Characteristics Impacting Process Feasibility</i>	<i>Reason for Potential Impact</i>	<i>Data Collection Requirements</i>	<i>Ref.</i>
<i>Feed particle size</i>	<i>Large particle size affects feeding and removal of solids from the bed. Solids greater than 1 inch (2.5 cm) must be reduced in size by shredding, crushing, or grinding. (Note Waste-Tech fluid bed systems can handle up to 3-in feed.) Fine particles (clays, silts) result in high particulate loading in flue gases.</i>	<i>Size, form, quantity of solid material; size reduction engineering data; soil particle size distribution; USGS soil classification</i>	<i>1,2,3, 4</i>
<i>Low-melting point (less than 1600°F) constituents, particularly alkali metal salts and halogens (e.g., Na, Cl compounds)</i>	<i>Defluidization of the bed may occur at high temperatures when particles begin to melt and become sticky. Melting point reduction (eutectics) may also occur. Alkali metal salts greater than 5% (dry weight) and halogen greater than 8% (dry weight) contribute to such refractory attack, defluidization, and slagging problems.</i>	<i>Ash fusion temperature</i>	<i>2,4</i>
<i>Ash content</i>	<i>Ash contents greater than 64% can foul the bed. (Note: Waste-Tech's continuous bed letdown, screening, and reinjection minimize this type of problem.)</i>	<i>Ash content</i>	<i>4</i>
<i>Waste density</i>	<i>As waste density increases significantly, particle size must be decreased for intimate mixing and heat transfer to occur.</i>	<i>Waste-bed density comparison</i>	<i>4</i>
<i>Presence of chlorinated or sulfonated wastes</i>	<i>These wastes require the addition of sorbents such as lime or sodium carbonate into the bed to absorb acidic gases or the addition of a flue gas scrubbing system as part of the treatment train.</i>	<i>Analysis for priority pollutants</i>	<i>4</i>

* See also Table A-1, High-Temperature Thermal Treatment (General).

A.2 Rotary Kiln Incineration

Technology Description

Rotary kiln incinerators are slightly inclined, refractory-lined cylinders. Their primary use is the combustion of organic solids and sludges, including SARA, RCRA, and other contaminated wastes. Rotary kiln incineration involves the controlled combustion of organic wastes under net oxidizing conditions (i.e., the final oxygen concentration is significantly greater than zero).

Wastes and auxiliary fuel are injected into the high end of the kiln and passed through the combustion zone as the kiln slowly rotates. Rotation of the combustion chamber creates turbulence and improves the degree of burnout of the solids. Retention time can vary from several minutes to an hour or more. Wastes are substantially oxidized to gases and inert ash within this zone. Ash is removed at the lower end of the kiln. Flue gases are passed through a secondary combustion chamber and then through air pollution control units for particulate and acid gas removal.

Although organic solids combustion is the primary use of rotary kiln incinerators, liquid and gaseous organic wastes can also be handled by injection into either the feed end of the kiln or the secondary combustion chamber. Wastes having high inorganic salt content (e.g., sodium sulfate) are not recommended for incineration in this manner because of the potential for degradation of the refractory and slagging of the ash. Similarly, the combustion of wastes with high toxic metal content can result in elevated emissions of toxic air pollutants, which are difficult to collect with conventional air pollution control equipment.

Residuals generated from this process are (1) ash from the low end of the kiln and in some cases from air pollution control devices such as hydrocyclones, (2) stack gases, and (3) brine solution from the ash quench and wet scrubber. More information on residuals management is included in Table 6.

Status: Rotary kiln incinerators, both fixed and mobile, are widely available commercially from many vendors and are in broad use for most hazardous waste applications, including RCRA, CERCLA, and other toxic substances.

Figure A.2-1 illustrates rotary kiln incineration, and Table A.2-1 is a technology restriction table.

EPA Contact:

Frank Freestone, (201) 321-6632, FTS 340-6639
U.S. Environmental Protection Agency
Risk Reduction Engineering Laboratory
Edison, NJ 08837

Vendor:

No specific names of vendors are listed here because the technology is widely available.

Figure A.2-1. Rotary kiln incineration.

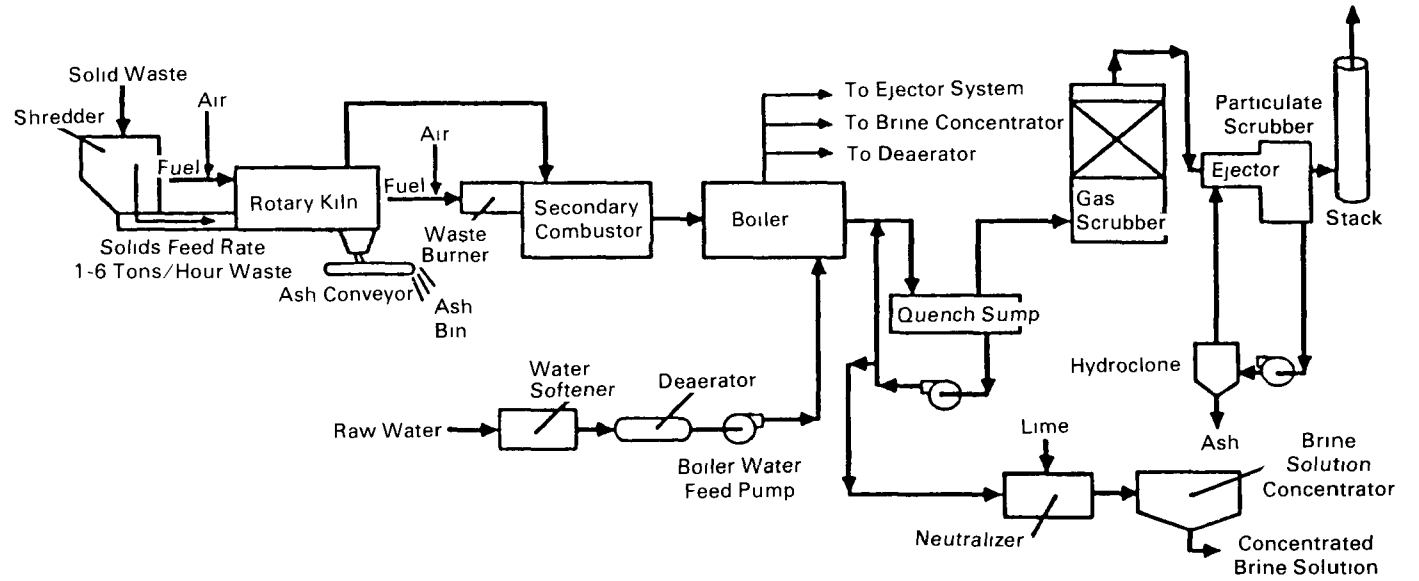

Source: ENSCO Environmental Services

Table A.2-1 Technology Summary.

Waste Type: Soils and Sludges
Technology: Rotary Kiln Incineration*

<i>Characteristics Impacting Process Feasibility</i>	<i>Reason for Potential Impact</i>	<i>Data Collection Requirements</i>	<i>Ref.</i>
<i>Oversized debris such as large rocks, tree roots, and steel drums</i>	<i>Difficult to handle and feed; may cause refractory loss through abrasion. Size reduction equipment such as shredders must be provided to reduce solid particle size.**</i>	<i>Size, form, quantity of oversized debris. Size reduction engineering data</i>	<i>2,3,4</i>
<i>Volatile metals (Hg, Pb, Cd, Zn, Ag, Sn)</i>	<i>May result in high metals concentration in flue gas, thus requiring further treatment.</i>	<i>Soil and stack gas analysis for subject metals</i>	
<i>Alkali metal salts, particularly sodium and potassium sulfate (NaSO₄, KSO₄)</i>	<i>Cause refractory attack and slagging at high temperatures. Slagging can impede solids removal from the kiln.</i>	<i>Percent Na, K</i>	<i>2,4</i>
<i>Fine particle size of soil feeds such as clay, silts</i>	<i>Results in high particulate loading in flue gases due to the turbulence in the rotary kiln.</i>	<i>Soil particle size distribution, USGS*** soil classification</i>	<i>1,4</i>
<i>Spherical or cylindrical wastes</i>	<i>Such wastes may roll through the kiln before complete combustion can occur.</i>	<i>Physical inspection of the waste</i>	<i>4</i>
<i>Ash fusion temperature of waste</i>	<i>Operation of the kiln at or near the waste ash fusion temperature can cause melting and agglomeration of inorganic salts.</i>	<i>Ash fusion temperature</i>	<i>4</i>
<i>Heating value of waste</i>	<i>Auxiliary fuel is normally required to incinerate wastes with a heating value of less than 8,000 Btu.</i>	<i>Btu content</i>	<i>5</i>

* See also Table A-1, High Temperature Thermal Treatment (General).

** See Tables 4 and 5.

*** U.S. Geological Survey.

A.3 Infrared Thermal Treatment

Technology Description

Infrared thermal units use silicon carbide elements to generate thermal radiation beyond the red end of the visible spectrum. Materials to be treated pass through the unit on a belt and are exposed to the radiation. Off-gases pass into a secondary chamber for further infrared irradiation and increased retention time. Flue gases are treated based on feed constituents and are emitted, as are ash and any scrubber effluents.

The infrared thermal treatment unit originally developed by Shirco Infrared Systems has a feed system and an infrared primary chamber with a continuous waste conveyor. From the primary chamber, combustion products flow into a secondary chamber, which can be either a combination gas-fired/infrared unit or a conventional secondary chamber. Flue gas treatment is accomplished by any conventional off-gas cleanup system. Infrared energy, or thermal radiation of wavelengths outside the visible light spectrum at the red end, is generated by silicon carbide resistance heating elements. The significant difference between an infrared unit and a rotary kiln is that the primary units (i.e., kiln or infrared) differs; the other parts of the systems are similar.

The primary process variables in the infrared system are temperature, residence time, waste material layer thickness on the conveyor belt, and combustion air flow. In the incineration mode, nominal operating temperatures are 1400°F and 1600°F in the primary and secondary chambers, respectively. In the pyrolysis mode, temperatures can be as low as 800°F. Optimum material thickness is 2 inches for throughput. Temperature and residence time are inversely related; residence times can vary from 5 to 50 minutes. Combustion air flow rate is adjusted to control combustion efficiency.

The residuals from this process, like those of other thermal treatment processes, are ash, scrubber water, and off-gases. The gases are scrubbed to remove acid components and particulates. Table 6 contains further information on residuals management.

Status: This technology has been used recently for the treatment of CERCLA wastes containing halogenated and nonhalogenated organics, including PCBs.

Figure A.3-1 illustrates infrared thermal treatment, and Table A.3-1 is a technology restriction table.

EPA Contact:

Howard Wall, (513) 569-7691, FTS 684-7691
U.S. Environmental Protection Agency
Risk Reduction Engineering Laboratory
Cincinnati, OH 45268

Vendors:

Scott Berdine, (214) 404-7540
Ecova Corporation
Park Central IX
12790 Merit Drive
Dallas, TX 75251

(Ecova Corporation has acquired a license to use the Shirco technology)

Saul Furstein, (404) 981-9332
Westinghouse Haztech, Incorporated
5280 Panola Industrial Blvd.
Decatur, GA 30035-4013

Samuel Insalaco, (419) 423-3526
OH Materials Corporation
P.O. Box 551
Findley, OH 45839

John Peterson, (503) 286-4656
Reidel Environmental Services
P.O. Box 507
Portland, OR 97205

Figure A.3-1. Infrared thermal treatment.

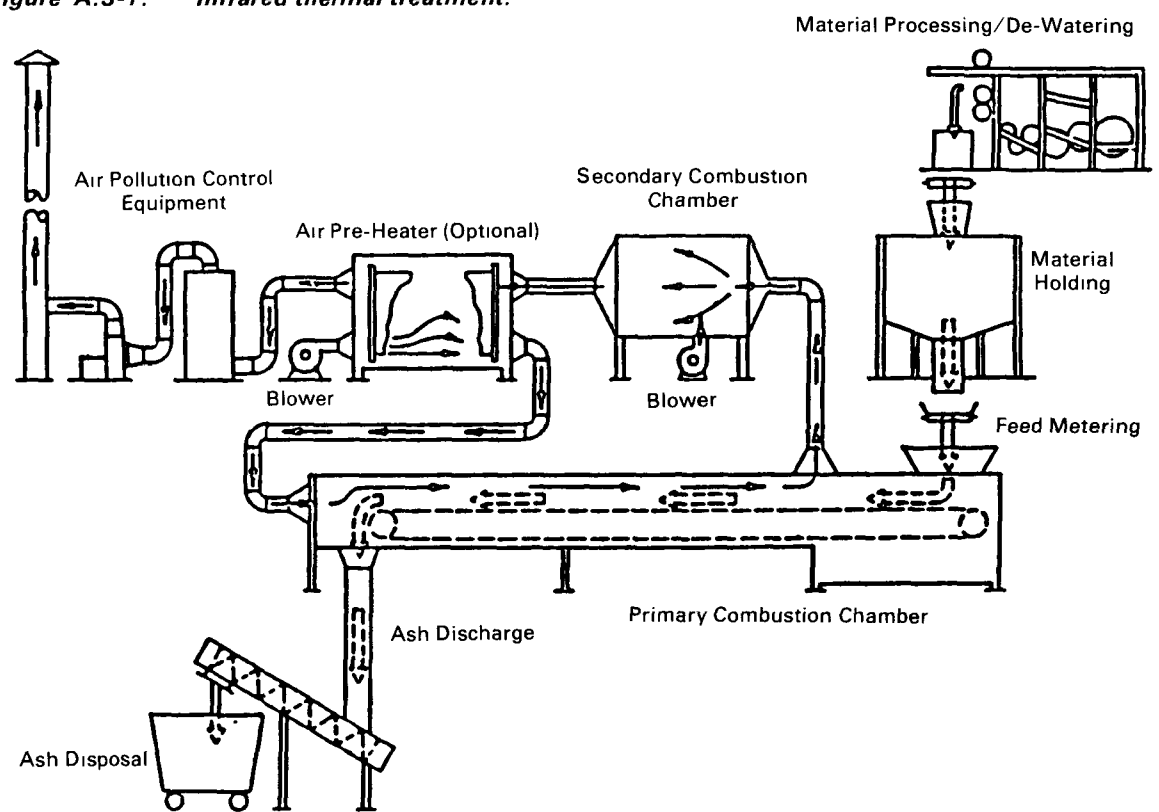

Source: Shirco Infrared Systems, Inc.

Table A.3-1 Technology Summary.

Waste Type: Soils and Sludges
Technology: Infrared Thermal Treatment*

<i>Characteristics Impacting Process Feasibility</i>	<i>Reason for Potential Impact</i>	<i>Data Collection Requirements</i>	<i>Ref</i>
<i>Nonhomogeneous feed size</i>	<i>Nonuniform feed size requires pretreatment before feeding and conveyance through the system. The largest solid particle size processible is 1 to 2 inches. Debris such as rocks, roots, and containers must be crushed or shredded to allow for feeding.**</i>	<i>Size, form, quantity of solid material; size reduction engineering data</i>	<i>3</i>
<i>Moisture content</i>	<i>Since waste material is conveyed through the system on a metal conveyor belt, soils and sludges must be firm enough (usually >22% solids) to allow for proper conveyance. Soils and sludges with excess water content (e.g., lagoon sediments) require dewatering prior to feeding.**</i>	<i>Moisture analysis</i>	<i>3</i>

* See also Table A-1, High Temperature Thermal Treatment (General).

** See Tables 4 and 5.

A.4 Wet Air Oxidation

Technology Description

Wet air oxidation is a thermal treatment technology that breaks down suspended and dissolved oxidizable inorganic and organic materials by oxidation in a high-temperature, high-pressure, aqueous environment. Wet air oxidation is used primarily to treat biological wastewater treatment sludges. It has, however, potential application to concentrated liquid or sludge waste streams containing organic and oxidizable inorganic wastes (including halogenated organics, inorganic/organic cyanide, and phenols in inorganic/organic sludges) that are not readily biodegradable. It can also be used to regenerate powdered activated carbon.

In this process, waste is mixed with compressed air. The waste-air mixture passes through a heat exchanger and then into the reactor, where oxygen in the air reacts with oxidizable material in the waste. In the heat exchanger, the raw waste and air mixture is heated to reaction conditions by indirect heat exchange with the hot oxidized effluent. The reaction is exothermic, and the heat liberated further raises the temperature of the reaction mixture to the design temperature. In cases in which the heat of reaction is insufficient to maintain the design operating temperature (because of a low influent concentration of oxidizable organics), additional heat may be necessary. This extra heat is added either by injecting startup steam into the reactor or by placing a startup heat exchanger before the reactor and after the feed heat exchanger. The exit stream from the reactor is passed through the heat exchanger, heating the incoming material. A separator is then used to separate the resultant gas stream from the oxidized liquid stream.

With halogenated organics, it may be necessary to use a catalyzed wet oxidation process. The major impact of a catalyst on the system is either to lower the reaction temperature or to increase the destruction efficiency.

The environmental impact of the gas, liquid, and solid effluent must be addressed when considering wet air oxidation for hazardous waste treatment. The oxidation products from treating toxic organic compounds are not entirely carbon dioxide and water. Some low molecular weight compounds, such as acetaldehyde, acetone, acetic acid, and methanol, are also formed. These compounds are distributed between the off-gas and oxidized liquid phase. Volatile organic components in the process off-gas can be controlled by a variety of technologies including scrubbing techniques, carbon adsorption, and fume incineration. The liquid effluent, containing predominantly carboxylic acids and other carbonyl group compounds, are readily treated by biological treatment or a combination of biological treatment and carbon adsorption. The liquid effluent will contain suspended solids, which are insoluble ash containing metal oxides and other insoluble salts such as sulfates, phosphates, and silicates. The insoluble ash can usually be dewatered and disposed of. See Table 6 for more detail on residuals treatment.

Modar has a technology that operates in the supercritical state of water (above 647 K and 22.1 MPa). Data indicate that faster reaction rates and higher efficiencies are obtained because gases, including oxygen, and organic substances are completely soluble in supercritical water.

Status: A pilot-scale Supercritical Water Oxidation Unit (by Modar) has been successfully demonstrated on RCRA wastes, including PCBs (Reference 6).

Figure A 4-1 illustrates wet air oxidation, Figure A.4-2 illustrates a Supercritical Water Oxidation Unit, and Table A.4-1 is a technology restriction table.

EPA Contact:

Harry M. Freeman, (513) 569-7529, FTS 684-7529
U.S. Environmental Protection Agency
Risk Reduction Engineering Laboratory
Cincinnati, OH 45268

Vendors:

William Copa, (715) 359-7211
Zimpro, Incorporated
Military Road
Rothschild, WI 54474

Fran Ferraro, (303) 452-8800
VerTech Treatment Systems
Westminster, CO 80234

K C. Swallow, Ph D., or Bill Killilea, (617) 655-7741
Modar, Incorporated
14 Tech Circle
Natick, MA 01760

Figure A.4-1 Wet air oxidation.

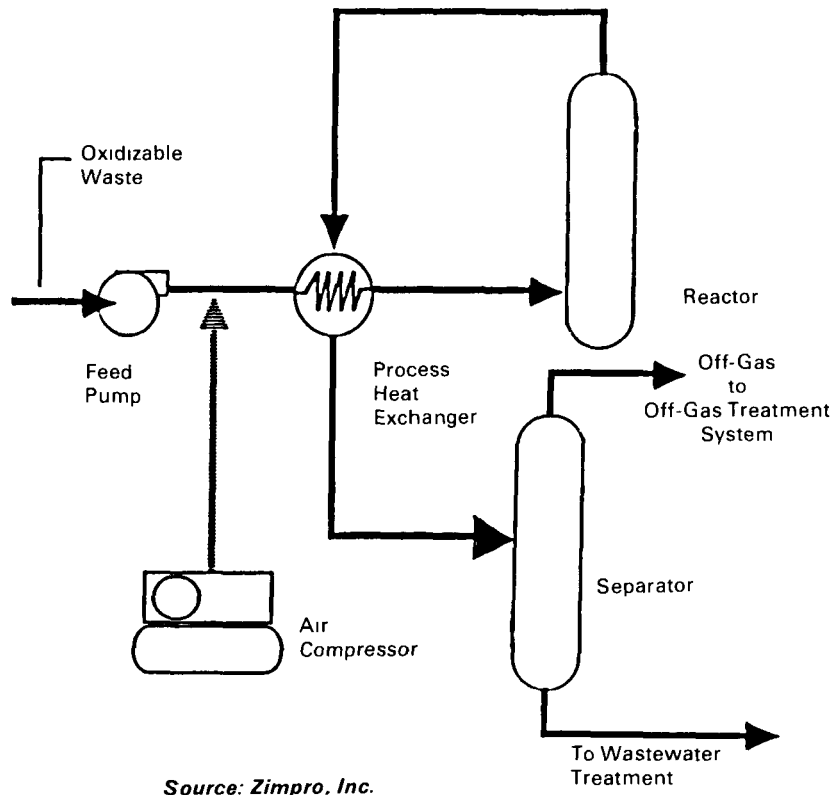

Source: Zimpro, Inc.

Figure A.4-2. Supercritical water oxidation unit.

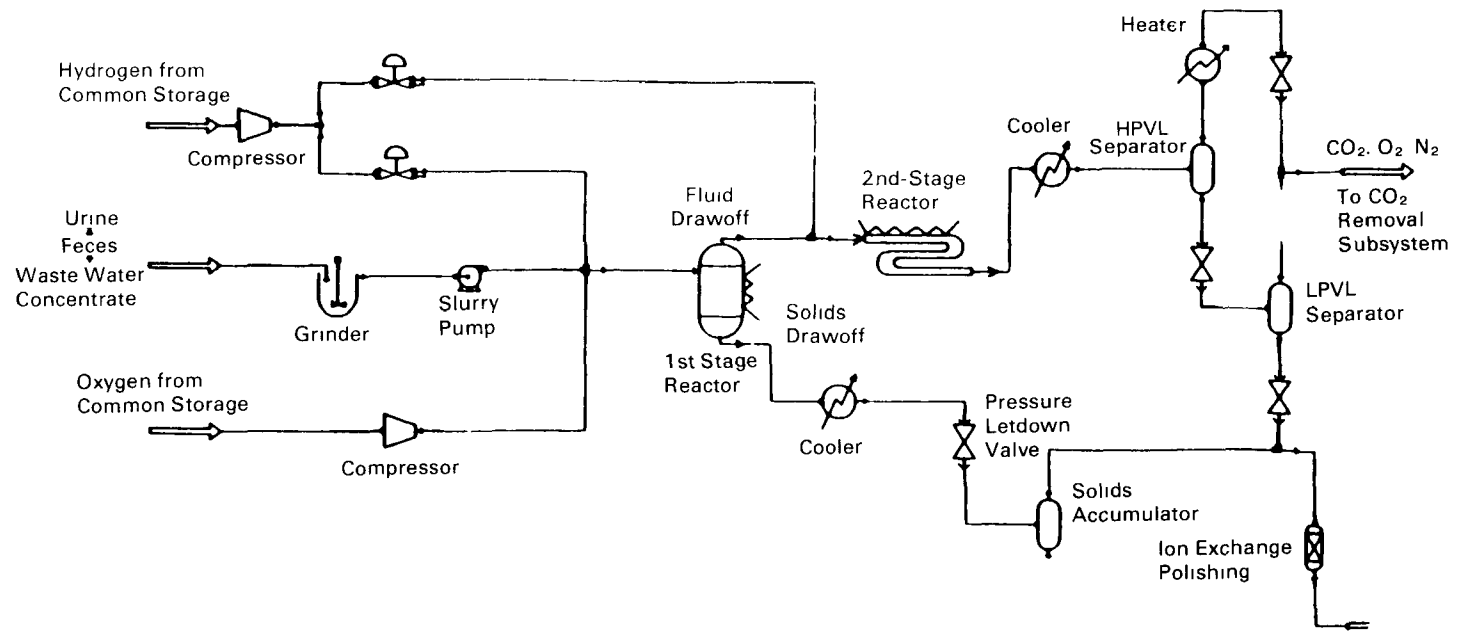

50

Source: Modar, Inc.

Table A.4-1 Technology Summary.

Waste Type: Sludges
Technology: Wet Air Oxidation

<i>Characteristics Impacting Process Feasibility</i>	<i>Reason for Potential Impact</i>	<i>Data Collection Requirements</i>	<i>Ref.</i>
Solids content	Solids should not unduly foul heat transfer surfaces.	Physical inspection	2,3
Viscosity of sludge	The waste must be in a pumpable liquid or liquid-like form, with a viscosity of less than 10,000 SSU.	Viscosity, total solids analysis, suspended solids analysis	2,3
COD < 100,000 mg/l COD > 200,000 mg/l	Wastes with COD concentrations outside this range are either too dilute or too concentrated for a feasible application.	COD analysis	2,3
Soluble metals	Soluble metals, for the most part, will remain in the liquid effluent after treatment. See pretreatment and residuals treatment tables.	Analysis for heavy metals	2,3
Volatile organics	Volatiles may be stripped from the aqueous phase before being oxidized. Requires off-gas treatment. See residuals treatment table	Analysis for volatile organics	**
Abrasive and/or acidic characteristics	Wastes that have high abrasive and/or acidic characteristics may require more expensive equipment and materials (e.g., titanium).	Treatability testing	2,3
Fluoride content < 0.1 g/l for stainless steel and titanium; chloride content < 20 g/l for titanium and < 1 g/l for stainless steel*	Corrosion of reactor.	Analysis for total halides	**
pH < 1 and > 12 for titanium or pH < 5 and > 12 for stainless steel	Corrosion of reactor. See pretreatment table.	pH analysis	**
Calcium and magnesium content less than 0.1 g/l	Can cause fouling of heat transfer surfaces.	Analysis for calcium and magnesium	**

* Data based on pilot-scale units. Higher limits are expected upon upscaling to field units.

** Information supplied by Modar, Inc.

A.5 Pyrolytic Incineration

Technology Description

Pyrolysis involves the destruction of organic material in the absence of oxygen at a high temperature to reduce toxic organic constituents to elemental gas and water. The absence of oxygen allows separation of the waste into an organic fraction (gas) and an inorganic fraction (salts, metals, particulates) as char material. The process conditions range from pure heating (thermolysis) to conditions in which only slightly less than the theoretical (stoichiometric) air quantity is supplied. Gases are the principle product generated by the pyrolytic reaction, although ash can also be generated.

The pyrolytic incineration process marketed by Midland Ross Corporation is a two-step process. In the first step, waste material is decomposed at 1000 to 1400°F into an organic gaseous fraction and an inorganic solid fraction in the absence of air, or oxygen. In the second step, the organic fraction is fed into a high-temperature, direct-fired incinerator operated at 2200°F, where hazardous elements from the organic fraction are destroyed and the clean, decontaminated gases are sent to an energy recovery device. This system is capable of handling drummed liquids, solids, or sludges with heating values ranging from 0 to 20,000 Btu/lb. For noncontainerized wastes or sludges, a continuous pyrolytic system is recommended.

Status: This technology is commercially available and used at the RCRA facilities; however, its application to CERCLA wastes has not been demonstrated commercially.

Figure A.5-1 illustrates a pyrolytic incineration system, and Table A.5-1 is a technology restriction table.

EPA Contact:

Ivars J. Licis, (513) 569-7718, FTS 684-7718
U.S. Environmental Protection Agency
Risk Reduction Engineering Laboratory
Cincinnati, OH 45268

Vendor:

Val Daiga, (419) 537-6125
Surface Combustion Division
Midland Ross Corporation
P.O. Box 907
Toledo, OH 4369-0907

Figure A.5-1 Pyrolytic incineration system.

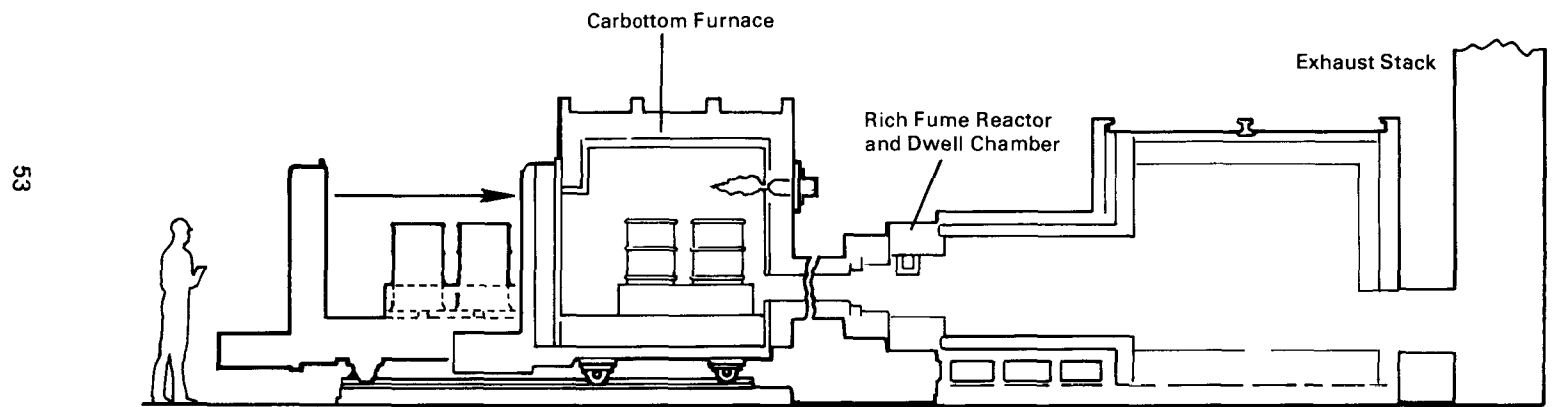

53

Source: Midland Ross Corp.

Table A.5-1 Technology Summary.

Waste Type: Soils and Sludges
Technology: Pyrolytic Incineration*

<i>Characteristics Impacting Process Feasibility</i>	<i>Reason for Potential Impact</i>	<i>Data Collection Requirements</i>	<i>Ref</i>
<i>High Btu organic waste</i>	<i>Desirable since energy recovery is the ultimate goal.</i>	<i>gas analysis</i>	<i>**</i>
<i>Temperature</i>	<i>First chamber requires temperature lower than 1400°F to capture gaseous organics.</i>	<i>temperature monitoring</i>	<i>**</i>

* See also Table A-1, High Temperature Thermal Treatment (General) for generic incineration restrictions.

** Information provided by vendor.

A.6 Vitrification

Technology Description

Vitrification thermal treatment is used to transform chemical and physical characteristics of hazardous waste such that the treated residues contain hazardous material immobilized in a vitreous mass. The destruction of the hazardous waste is achieved in a reaction chamber in which high temperature is used to reduce toxic organic compounds to elemental gas (CO, H₂) and carbon. Inorganic contaminants should remain entrained in the glass and siliceous melts. The advantages of vitrification over other thermal processes are the lack of oxidation products and large air emissions and the reduced leachability of inorganic materials, such as heavy metals.

The reaction chamber is divided into upper and lower sections, both of which are refractory-lined and have separate electric (480-volt, 3-phase) heating systems. The upper section accepts the waste feed via gravity and contains gases and other products of pyrolysis; the lower section contains the two-layer molten zone for the melts of the metal and siliceous components of the waste.

For solid waste treatment, the feed--limited to 4 inches--is gravity fed on a conveyor into the reactor. The wastes are destroyed at a nominal temperature of 3002°F or 1650°C (+/- 104°F or 40°C). The off-gas and particulates are drawn off by an induction fan and treated through a cyclone, a baghouse, and an acid gas scrubber. Solid waste is withdrawn from the lower section of the chamber via separate molten glass and metal taps. Both particulate and gas streams can be recycled to the reactor.

The residue streams from the vitrification unit are molten glass, molten metal, scrubber water, and off-gas. The concentrations of hazardous constituents in the residuals are such that further treatment is not required. More detail on these residuals is provided in Table 6.

The Westinghouse electric pyrolyzer is a pyrolytic thermal process developed for the destruction of hazardous waste solids, such as contaminated soils and sludges, with concentrations of organics and water up to 10 percent and 25 percent, respectively. The process involves the destruction of organic material in the absence of oxygen.

Another vitrification process, promoted by Vitrifix of North America, is presently demonstrated for rendering asbestos nontoxic by thermal decomposition. The vitrifix furnace temperature is maintained above 1300°C. If the temperature falls toward 1100°C, the resulting glass becomes increasingly viscous. In this system, asbestos is thermally decomposed at temperature below 900°C. Thus a temperature safety margin of 200°C prevents unconverted asbestos from leaving the furnace. The product of the process is silicate glass, dark green to black in color. The Vitrifix furnace unit is a transportable system that comes in three different sizes up to 2 tonnes/day, 2-10 tonnes/day, and >10 tonnes/day. This method is presently used commercially in the United Kingdom to destroy asbestos-containing soils, including debris, and to treat low-level radioactive waste. A 2-tonne per day unit has been used under the supervision of EPA to destroy asbestos-containing soils with feed size less than 1 inch. The transportable system is not currently available in this country commercially. Vitrifix is also developing the technology for application to heavy metals in soils and fly ash. Metals such as Fe⁺², Cr, Ni, and Hg are a problem, and incorporation of an additional process step is required.

A third vitrification technology, marketed by Retech as a centrifugal reactor, offers indirect heating of solid and liquid organic wastes via electric conductance from a plasma torch. A high temperature of 2,800°F is achieved, and at this temperature liquid components of the waste are volatilized, reducing the organic constituents to carbon monoxide, hydrogen, and hydrochloric acid, and, in some cases, reducing all the way to carbon dioxide and water. The volatilized components are captured and are treated in a gas scrubber unit. Metals and small amounts of solid carbon remain in the vitrified combustion residue. If the residue analysis indicates that hazardous organic constituents remain in the residue, then it is recycled and treated again in the reactor. The vendor claims that the volume of the waste is reduced by a factor of 20. This technology can be used to treat a sludge or soil contaminated with PCBs or another high-solids content waste.

Status: A commercial Westinghouse prototype was tested on Superfund wastes in September 1986; the process is expected to be commercially available in 1989. Vitrifix has demonstrated a small-scale commercial plant on asbestos waste and is constructing a fixed, full-scale commercial facility for asbestos-containing materials. Retech has a prototype unit not yet demonstrated on RCRA or CERCLA waste.

Figures A.6-1 and A.6-2 illustrate vitrification systems, and Table A.6-1 is a technology restriction table.

EPA Contact:

Ivars J. Licis, (513) 569-7718, FTS 684-7718
U.S. Environmental Protection Agency
Risk Reduction Engineering Laboratory
Cincinnati, OH 45268

Vendors:

William H. Reed, (412) 722-5303
Westinghouse Electric Corporation
Environmental Technology Division
Box 286
Madison, PA 15663-0286

David Roberts, (703) 684-1090
Vitrifix North America
1321 Duke Street, Suite 304
Alexandria, VA 22314

John Pariola, (707) 462-6522
Retech, Incorporated
P.O. Box 997
100 Henry Station Road
Ukiah, CA 95482

Figure A.6-1. Vitrification ("electric pyrolyzer").

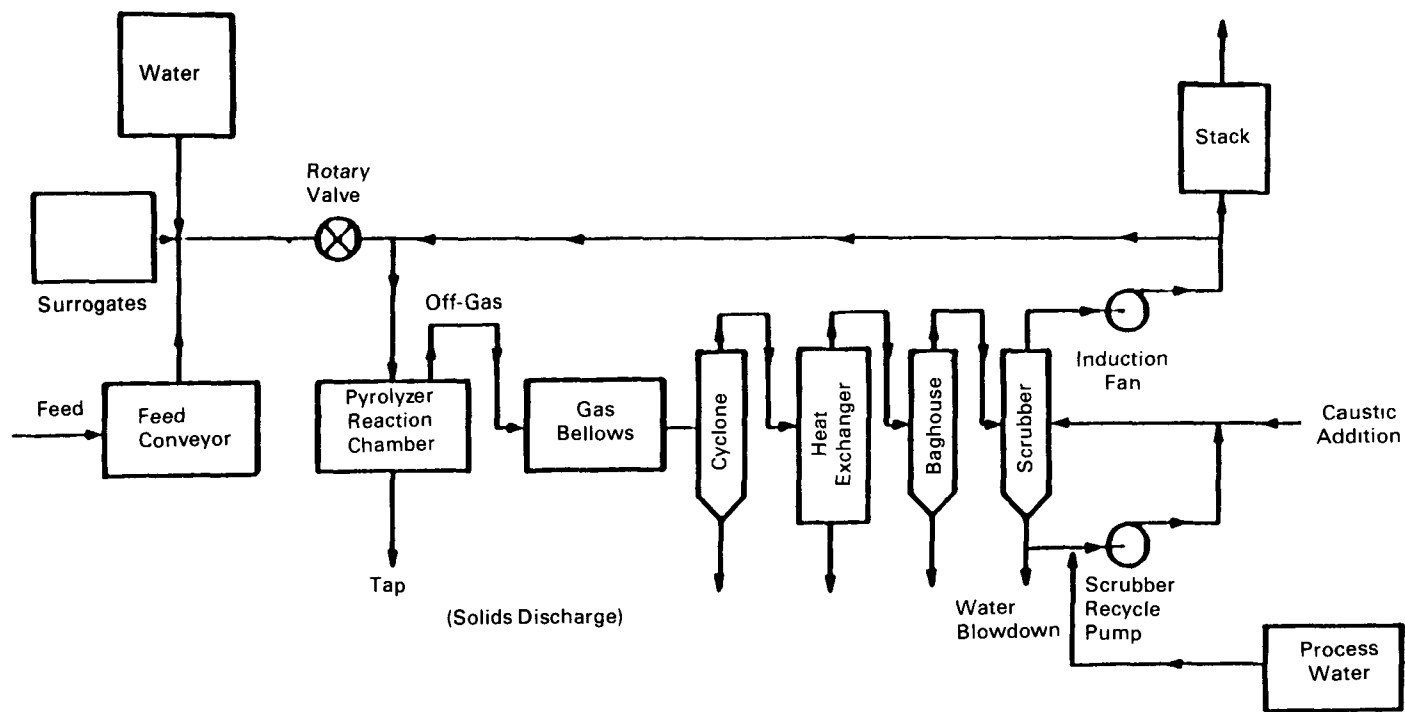

Source: Westinghouse Electric Corp.

Figure A.6-2. Vitrification ("pyrolytic centrifugal reactor").

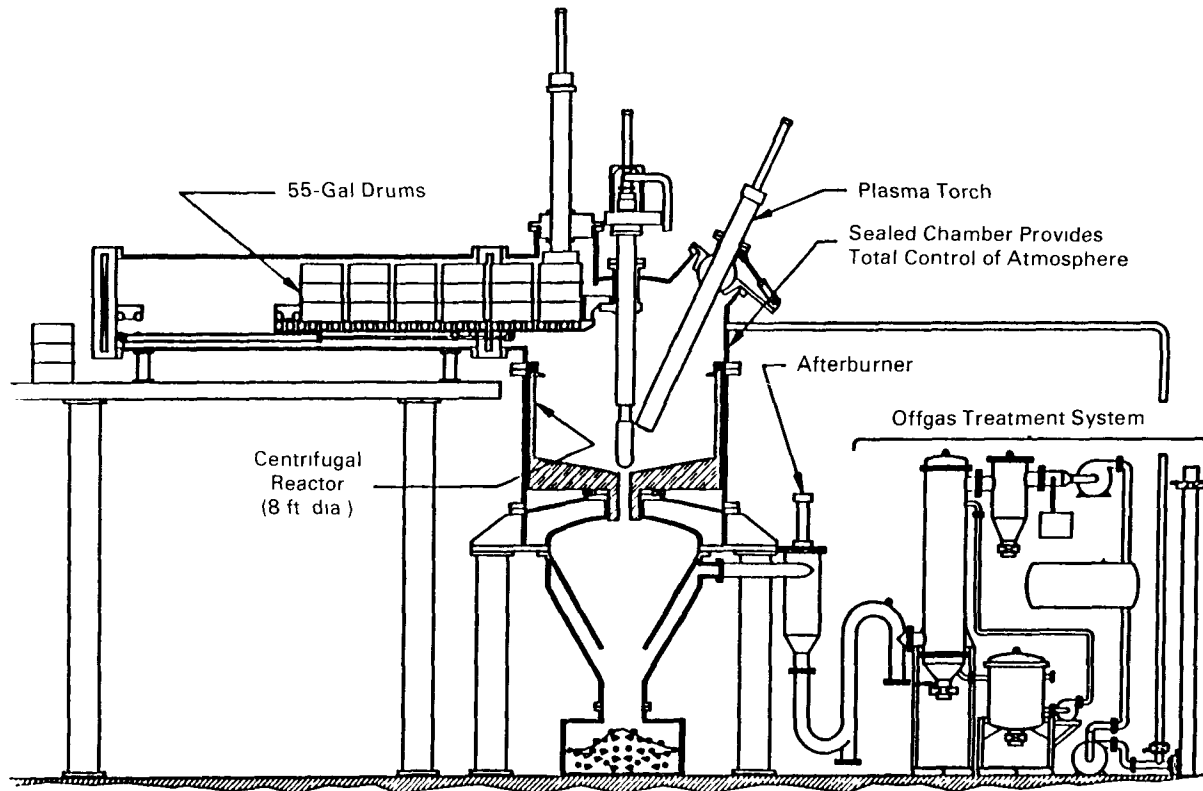

Source: Retech, Inc.

Table A.6-1 Technology Summary.

Waste Type: Soils and Sludges
Technology: Vitrification

<i>Characteristics Impacting Process Feasibility</i>	<i>Reason for Potential Impact</i>	<i>Data Collection Requirements</i>	<i>Ref.</i>
<i>Feed compatibility (particle size)</i>	<i>Large particle size undesirable. Size reduction is required, nominally to 4 inches.</i>	<i>Particle size distribution</i>	<i>*</i>
<i>Maintainability and reliability</i>	<i>Full-scale units need to be operated in the field to demonstrate technology effectiveness.</i>	<i>Field operating data</i>	<i>*</i>
<i>Gas emissions</i>	<i>Monitoring for PICs and metals emission and to demonstrate DRE.</i>	<i>Hydrogen concentration, oxygen concentration, organics and inorganics concentrations</i>	<i>*</i>
<i>Moisture content</i>	<i>Maximum of 25% water by weight.</i>	<i>Analysis moisture</i>	<i>*</i>
<i>Organic content</i>	<i>Organic content limited to 10%.</i>	<i>Analysis for total organic content</i>	<i>*</i>
<i>Metals</i>	<i>Presence of mercury and cadmium undesirable</i>	<i>Analysis for metals</i>	<i>**</i>
<i>Particulate air emission</i>	<i>Particulate air emissions required to be captured in gas scrubbing system</i>	<i>Monitoring for air emissions</i>	<i>**</i>

** Information supplied by Westinghouse.*

*** Information supplied by Retech.*

References

- (1) Niessen, Walter R. 1978. *Combustion and incineration processes*. New York, N.Y.: Marcel Dekker, Inc.
- (2) USEPA. 1986. U.S. Environmental Protection Agency, Office of Solid Waste and Emergency Response. *Mobile treatment technologies for Superfund wastes*. #540/2-86/003(f). Washington, D.C.: U.S. Environmental Protection Agency.
- (3) USEPA. 1986. U.S. Environmental Protection Agency, Office of Solid Waste and Emergency Response. *Superfund treatment technologies: a vendor inventory*. #540/2-86/004. Washington, D.C.: U.S. Environmental Protection Agency.
- (4) Versar Inc. 1985. Assessment of treatment technologies for hazardous waste and their restrictive waste characteristics. Vol. 1A-D. Washington, D.C.: U.S. Environmental Protection Agency, Office of Solid Waste.
- (5) Versar Inc. 1986. Assessment of technological options for management of hazardous wastes: chemical monographs for the First Third P and U waste codes. Vol. 1. Washington, D.C.: U.S. Environmental Protection Agency, Office of Solid Waste.
- (6) Staszak, C.N., Malinowski, K.C., and Killilea, W.R. The pilot-scale demonstration of the MODAR oxidation process for the destruction of hazardous organic waste materials. *Environmental Progress*. Vol. 6, No. 1 (February 1987):39 ff.

Appendix B

Physical/Chemical Treatment Technologies

Introduction

This appendix describes the applications and restrictions of physical/chemical treatment technologies for the cleanup of hazardous waste sites. These treatment technologies are widely used in industrial waste treatment and pretreatment. Thus, more complete descriptions of the processes can be found in the literature.

Physical treatment processes separate the waste stream by either applying physical force or changing the physical form of the waste, while chemical treatment processes alter the chemical structure of the constituents to produce a waste residue that is less hazardous than the original waste. Further, the altered constituents may be easier to remove from the waste stream. The physical/chemical treatment processes presented in this appendix are:

- Chemical extraction;
- In situ decontamination;
- Soil washing;
- In situ soil flushing;
- Glycolate dechlorination;
- Low temperature thermal stripping;
- In situ vacuum and steam extraction;
- Stabilization/solidification;
- Chemical reduction-oxidation; and
- In situ vitrification.

As discussed under many of the other treatment technologies, physical treatment processes will also produce residuals that must be disposed of in an environmentally safe manner. Treatment sludges may require additional treatment either on site or off site prior to disposal. Treatment needed may include dewatering (and subsequent treatment of wastewater) and immobilization.

The further treatment required for concentrated solids and sludges will depend on the type and level of contamination. A number of thermal, physical, chemical, and immobilization processes may be used as treatment alternatives. Liquids will also require further treatment if hazardous constituents, such as volatile organics, are present.

Treatment sludges from any of these processes may require additional treatment either on site or off site prior to disposal. Treatment needed may include dewatering (and subsequent treatment of water) and immobilization. Depending upon the applicable requirements, solid residuals can be disposed of on site or off site.

This appendix contains information on individual physical/chemical treatment technologies. For each technology, a technology description is provided, followed by an illustration of the process and a technology restriction table. Each technology restriction table includes a listing of the

characteristics impacting the feasibility of the process, reasons for restriction, data collection requirements, and references. The numbers in the "Reference" column are correlated with the list of references included at the end of this appendix.

B.1 Chemical Extraction

Technology Description

The chemical extraction processes are used to separate contaminated sludges and soils into their respective phase fractions: organics, water, and particulate solids. One demonstrated process, Basic Extraction Sludge Treatment (BEST), developed by Resources Conservation Company, has been used primarily to treat oily sludges containing hydrocarbons and other high-molecular weight organics. This process has not been used to treat soils. Another process that is available to treat aqueous waste and sludges is known as solvent extraction with liquified gas.

In the BEST process, a secondary or tertiary amine (usually triethylamine, TEA) solvent is mixed at cool temperatures with soils or sludges. Depending on the waste matrix, waste may need slurring, which is achieved as part of the treatment train. At the low temperature the solvent is simultaneously miscible with oil and water. The solvent extracts organics adsorbed on the particles. The resulting mixture is centrifuged or filtered to separate the oil-extracted solids from the liquid phase. The solids are dried to recover the solvent for recycle within the system.

The particulate-free solvent/oil/water solution is heated, breaking any emulsions present and separating the organic and aqueous fractions by reducing their mutual solubility. The heated two-phase solution is decanted. The top fraction leaving the decanter is primarily solvent and oil, which are sent to a stripping column where solvent is recovered and oil is discharged. Some volatile organics, such as acetone, toluene, or methyl ethyl ketone, may boil off with the amine, requiring an additional selective distillation step. The bottom fraction, predominantly water, is sent to another stripping column to remove residual solvent. The contaminated oil is further treated, if necessary.

The waste, whether sludge or soil, commonly requires pretreatment before solvent addition. It may be necessary to add water or solvent to the waste so that it becomes pumpable. The process requires alkaline conditions, generally a pH of 10, so that TEA can exist. Alkaline conditions are created by a front-end neutralization step in which caustic soda is added to the feed stream to raise the pH. This step has the added advantage of insolubilizing any heavy metals existing in the aqueous phase. TEA is a weak base that can also be used to raise the pH of the feed stream by forming triethylammonium salts; however, this option is not usually cost effective. See Table 5 for more details concerning pretreatment options.

The BEST process produces an aqueous effluent stream, dry solids, waste oil, and solvent. The solvent is recycled back to the treatment system. The aqueous effluent may require biological treatment or carbon adsorption to remove residual organics before final discharge. If soluble metals are present in concentrations above allowable discharge limits, chemical precipitation will also be needed. The recovered waste oil should be analyzed to determine suitability for recycle or reuse as fuel. If neither option is viable, the waste oil must be incinerated. The residual solids are essentially free of mobile organics. Extraction tests should be conducted on the residual solids to determine the need for stabilization before their final disposal. See Table 6 for further details concerning residuals treatment options.

Critical fluid solvent extraction with liquified gas technology has been developed by CF Systems Corporation. Liquified gases (carbon dioxide and

propane) at high pressure are used to extract oils and organic solvents from wastewater and sludge in a continuous process. The evaporated gases are recycled following recompression. This technology is similar to supercritical fluid extraction.

CF Systems has operated a small-scale unit to extract dissolved and emulsified organics from aqueous waste. A small-scale sludge deoiling unit is available and has been used for the extraction of heavy oil from sludge. The material must be pumpable. The ideal pressure is 250 psi for propane and 950 psi for carbon dioxide and ambient temperature for extraction of organics. In order to use this technology for solids or soils treatment, the material must be slurried so that it can be pumped into the unit.

Using this technology, aqueous-based oily sludges or PCB-contaminated surface impoundment sludges can be treated. Materials that are primarily contaminated with heavy metals or inorganic compounds are not appropriate for this technology.

Status: A 100-ton per day BEST unit has been successfully used at a CERCLA cleanup site to treat PCB-contaminated oily sludge. CF Systems plans to demonstrate the small-scale sludge deoiling unit on PCB-contaminated sediments in 1988.

Figure B.1-1 illustrates chemical extraction, and Table B.1-1 is a technology restriction table.

EPA Contact:

Edward Bates, (513) 569-7774, FTS 684-7774
U.S. Environmental Protection Agency
Risk Reduction Engineering Laboratory
Cincinnati, OH 45268

Vendors:

Paul McGough, (206) 828-2400
Resources Conservation Company
3101 N.E. Northup Way
Bellevue, WA 98004

Thomas Cody, (617) 890-1200
CF Systems Corporation
140 Second Avenue
Waltham, MA 02154-1100

Figure B.1-1. Chemical extraction ("BEST").

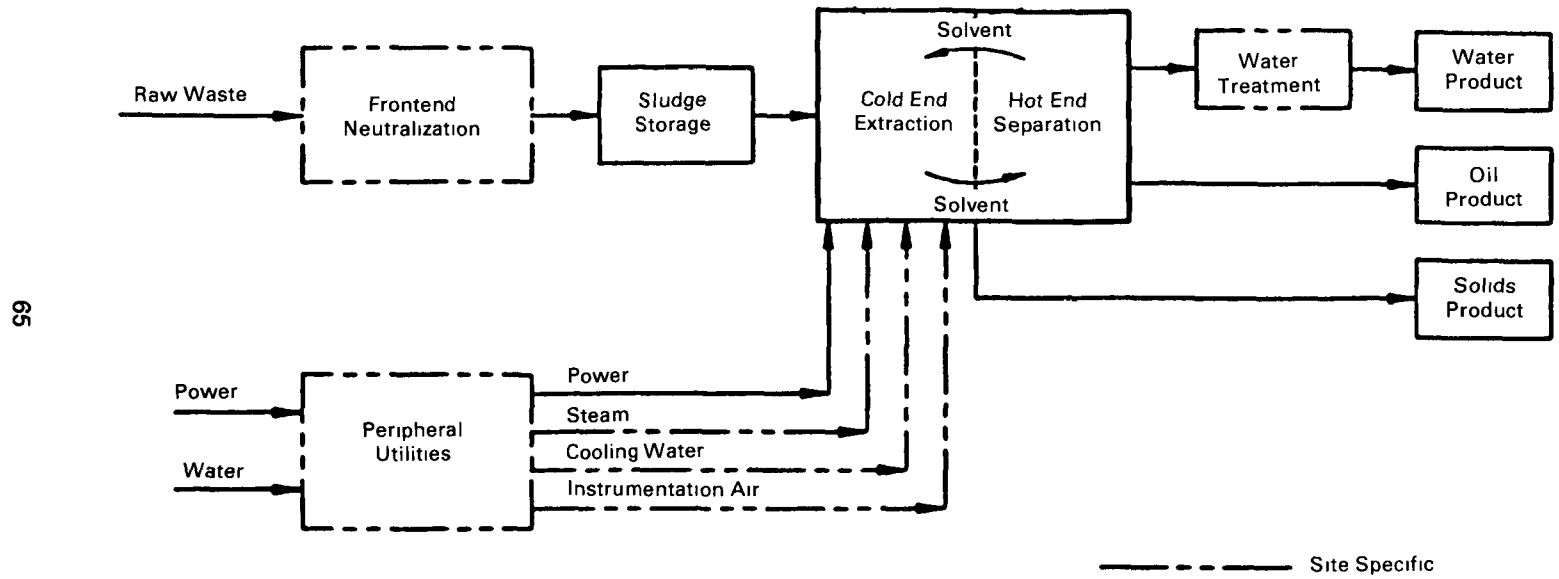

Source Resources Conservation Company

Figure B.1-2. Critical fluid solvent extraction.

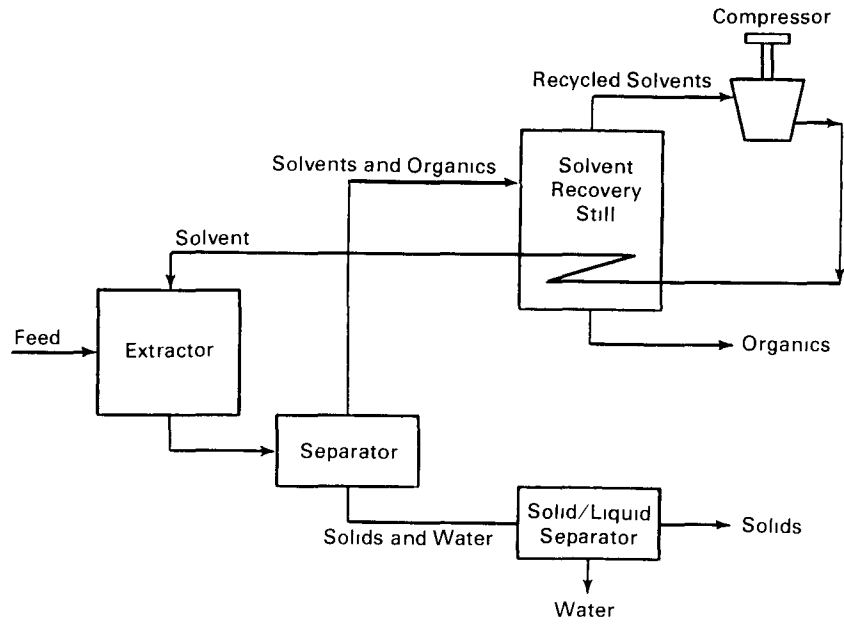

Source: CF Systems, Corporation

Table B.1-1 Technology Summary.

Waste Type: Soils and Sludges
Technology: Chemical Extraction

<i>Characteristics Impacting Process Feasibility</i>	<i>Reason for Potential Impact</i>	<i>Data Collection Requirements</i>	<i>Ref.</i>
<i>Presence of elevated levels of volatiles</i>	<i>Volatiles may combine with process solvent, requiring an additional separation step.</i>	<i>Volatile organic analysis</i>	<i>*</i>
<i>Particle size greater than 1/4 inch</i>	<i>Equipment used in process not capable of handling large particle size. (See pretreatment table for size reduction techniques.) Waste must be pumpable.</i>	<i>Particle size distribution</i>	<i>*</i>
<i>pH < 10</i>	<i>TEA (used in BEST process) is weak base and will exist in solvent form only at approximately pH ≥ 10. Wastes with lower pH must be pretreated to raise pH. See pretreatment table.</i>	<i>pH measurement</i>	<i>*</i>
<i>Presence of high amounts of emulsifiers</i>	<i>Adversely impact oil/water phase separation. A greater quantity of solvent is required for appropriate treatment</i>	<i>Glassware process simulation to measure phase separation characteristics</i>	<i>*</i>
<i>Metals (e.g., aluminum) or other compounds that undergo strong reactions under highly alkaline conditions</i>	<i>Strong reactions may occur during treatment process because of caustic addition. The adverse reaction may be avoided by using TEA for pH adjustment.</i>	<i>Analysis for aluminum</i>	<i>*</i>
<i>Types of waste</i>	<i>Materials contaminated with heavy metals not suitable. Wastes that are reactive with carbon dioxide and propane must be pretreated.*** Wastes containing > 200 ppm organics and oil concentration up to 40 percent are acceptable.</i>	<i>Metals analysis</i>	<i>**</i>

* Information supplied by Resources Conservation Co.

** Information supplied by CF Systems Corp.

*** See Tables 4 and 5.

B.2 In Situ Chemical Treatment

Technology Description

In situ chemical treatment allows treatment of contaminated soils and waste deposits in place. By using this treatment method a wide range of treatment agents, including solvents, precipitating and neutralizing chemicals, and stabilizing agents, can be delivered directly to the waste source. These treatment agents can be used to treat many types of contaminants, including petroleum hydrocarbons, chlorinated hydrocarbons, metals, PCBs, and radionuclides.

In situ soil decontamination using a wide variety of chemicals is marketed by Toxic Treatment (USA), Inc. under the trade name Detoxifier. The Detoxifier is a mobile treatment unit capable of neutralization or pH adjustment by the addition of acids or bases; destruction or chemical modification of contaminants via the use of oxidizing or reduction chemicals; and solidification/stabilization by the addition of chemicals or physical agents. Other applications include the addition of nutrients, microorganisms, and oxygen to promote in situ biodegradation and air or steam stripping of volatile contaminants.

The Detoxifier unit consists of a process tower, a control unit, and a process treatment train. These components are custom designed and configured to meet site-specific requirements. The process tower accomplishes the drilling and dispenses the remediation agents. The process tower is capable of penetrating the soil/waste medium to depths of more than 30 feet. Remediation agents (in dry, liquid, vapor or slurry form) are added to and mixed with the soil/waste at various depths during the upward and/or downward movements of the drill head assembly. A rectangular shroud, under vacuum, covers the drill head assembly to isolate the treatment area and prevent any environmental release. On-line analytical instruments continuously monitor the treatment conditions. The remediation of a large area is affected by a block-by-block treatment, approximately 30 square feet per block.

Another technology using a combination of direct delivery system and drilling is a deep soil mixing (DSM) system developed by Geo-Con Corporation. The system consists of a set of crane-supported leads which guide a series of mixing paddles and augers, hydraulically driven. As the ground is penetrated, stabilizing agents or other fluids are fed through the center of each shaft. The auger flights break the soil loose and lift it to the mixing paddles, which blend the additives with the soil. The augers are positioned to overlap each other and form a continuous block. As the augers advance to a greater depth, the soil and agent are remixed by additional mixing paddles on each shaft. When the desired depth is reached, the augers are withdrawn, and the mixing process is repeated on the way to the surface. Each auger is 36 inches in diameter, and there are four shafts together on 27-inch centers. The four shafts treat approximately three square yards of area per stroke. Each shaft is supplied with 40,000 foot pounds of torque. The DSM system can be used in almost any soil type; however, the more fines in the soil, the more mixing is required. The system can be used below the water table, and very soft rock formations can be drilled and mixed. Large obstructions such as buried concrete blocks, boulders, or pilings, must be avoided, but rocks less than one foot in diameter can be mixed. Objects such as drums, trash, and bottles may be broken up and penetrated.

Potential applications for in situ remediation in general include treatment of metals and radionuclides (mining mill tailings) by neutralization,

precipitation, and solidification/stabilization; and treatment of hydrocarbons, metals, and radionuclides by oxidation/reduction.

Status: Toxic Treatment's process is commercially available and has been demonstrated successfully on RCRA sites but has not been used at Superfund sites to date. A demonstration is scheduled to occur in late 1988 in California at a State Superfund site. Solidification/stabilization using the Geo-Con/DSM system has been demonstrated on PCB-contaminated soils.

Figure B.2-1 is a process diagram for Toxic Treatment's in situ chemical treatment system. Table B.2-1 is a technology restriction table.

EPA Contacts:

Mary Stinson, (201) 321-6683 FTS 340-6683
U.S. Environmental Protection Agency
Risk Reduction Engineering Laboratory
Edison, NJ 08837

Paul dePercin, (513) 569-7797
U.S. Environmental Protection Agency
Risk Reduction Engineering Laboratory
Cincinnati, OH 45268

Vendors:

Michael Ridosh, (415) 572-2994
Toxic Treatment (USA) Incorporated
901 Mariner's Island Blvd. Suite 315
San Mateo, CA 94404

Brian Jasperse, (412) 856-7700
Geo-Con, Incorporated
P.O. Box 17380
Pittsburgh, PA 15235

Figure B.2-1. In situ chemical treatment ("Detoxifier").

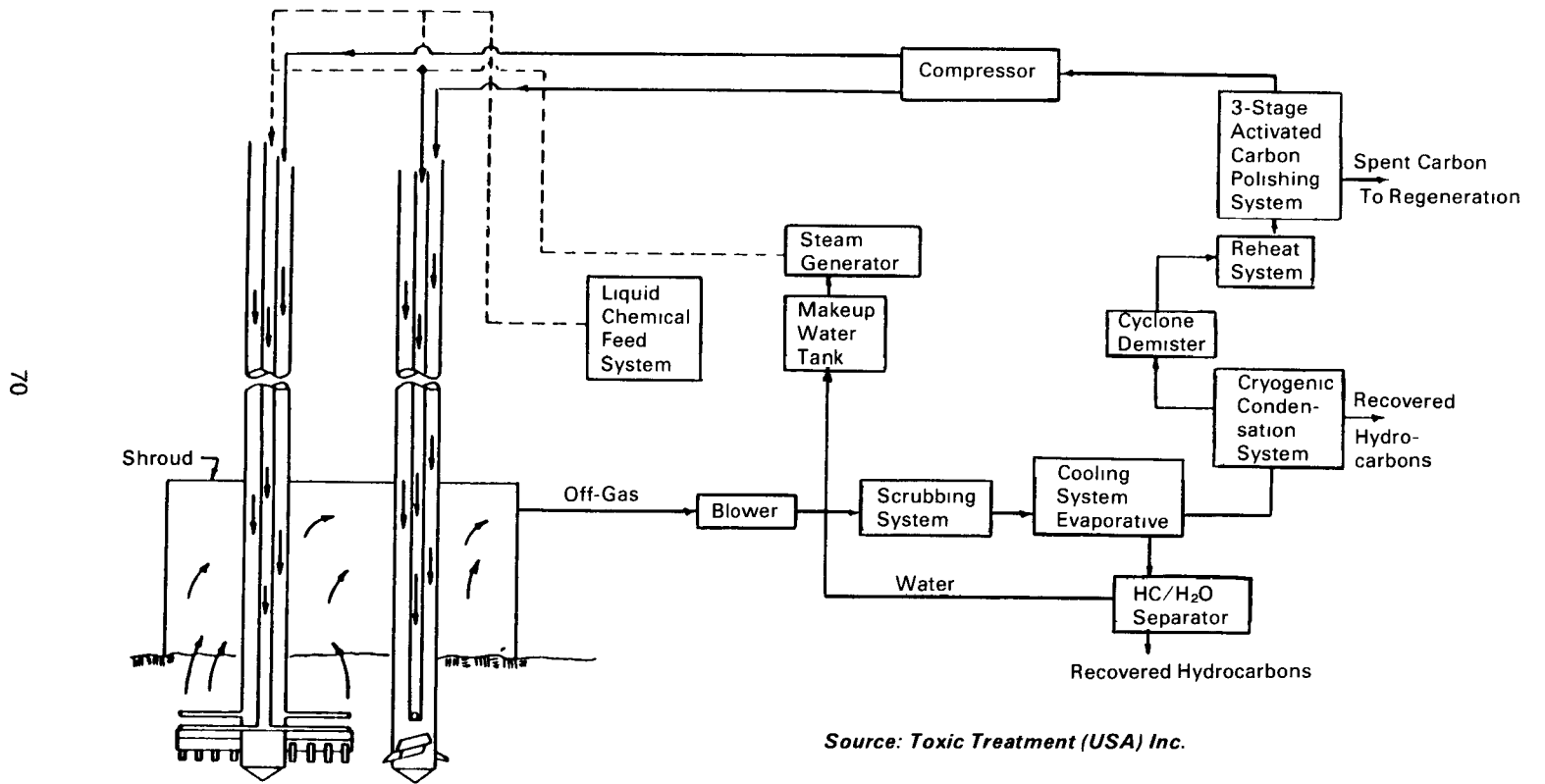

Table B.2-1 Technology Summary.

Waste Type: Soils and Sludges
Technology: In Situ Chemical Treatment

<i>Characteristics Impacting Process Feasibility</i>	<i>Reason for Potential Impact</i>	<i>Data Collection Requirements</i>	<i>Ref.</i>
<i>Site characteristics</i>	<i>Site must be level and flat with few underground obstructions.</i>	<i>Topography assessment</i>	<i>*</i>
<i>Type of soil</i>	<i>Sandy loam soil preferred to clay; fines require more mixing.</i>	<i>Soil analysis</i>	<i>*</i>

** Information supplied by Toxic Treatments (USA), Inc..*

B.3 Soil Washing

Technology Description

The soil washing process extracts contaminants from sludge or soil matrices using a liquid medium such as water as the washing solution. This process can be used on excavated soils that are fed into a washing unit. The washing fluid may be composed of water, organic solvents, water/chelating agents, water/surfactants, acids, or bases, depending on the contaminant to be removed. In contrast, in situ soil washing is performed on unexcavated soils and consists of injecting a solvent or surfactant solution to enhance the contaminant solubility, resulting in increased recovery of contaminants in the leachate or ground water (see B.4).

EPA's mobile extraction system uses water as the washing fluid. Contaminated soil enters the system through a feeder, where oversized nonsoil materials and debris that cannot be treated are removed with a coarse screen. The waste passes into a soil scrubber, where it is sprayed with washing fluid. Soil particles greater than 2 mm in diameter are sorted and rinsed, leave the scrubber, and are dewatered. The remaining soil enters a countercurrent chemical extractor, where additional washing fluid is passed countercurrent to the soil flow, removing the contaminants. The treated solids are then dewatered. The remainder of the process is a multistep treatment for removal of contaminants from the washing fluid prior to its recycling. Treatment is generally accomplished by conventional wastewater treatment systems depending on the type of contamination. See Table 6 for residuals management techniques.

A soil washing process developed by MTA Remedial Resources, Inc. (MTARRI) utilizes technology transfers from both the mining and enhanced oil recovery fields to simultaneously remove and concentrate the organic contaminants from soils. Release of contaminants from clay and sand is accomplished through alkaline and surfactant addition, which results in changing the interfacial tension. The treatment residues, detoxified soil, can be returned to the site and the treatment byproducts, concentrated organics, require either incineration, landfilling, or additional treatment for ultimate contaminant removal. This technology has been also demonstrated to remove metallic compounds of lead, cadmium, chromium, copper, and nickel. This technology is commercially available. Restoration of aquifers contaminated with aromatic, aliphatic, and/or organo-chlorides is accomplished using alkaline agents, surfactants, and biodegradable polysaccharides. The vendor claims that 5 tons of treatment residue is generated per 100 tons of soil treated.

Status: Two mobile units are commercially available. This technology is currently used at Department of Defense sites as a modified air stripper to treat volatiles. Two mobile units will be operational by the end of 1988.

Figures B.3-1 and B.3-2 illustrate soil washing systems, and Table B.3-1 is a technology restriction table.

EPA Contact:

Richard Traver, (201) 321-6677, FTS 340-6677
U.S. Environmental Protection Agency
Risk Reduction Engineering Laboratory
Edison, NJ 08837

Vendors:

Paul B. Trost, (303) 279-4255
MTA Remedial Resources, Inc.
1511 Washington Avenue
Golden, CO 80401

Al Bourquin, (206) 883-1900
Ecova Corporation
3820 159th Avenue NE
Redmond, WA 98052

Figure B.3-1. Soil washing system.

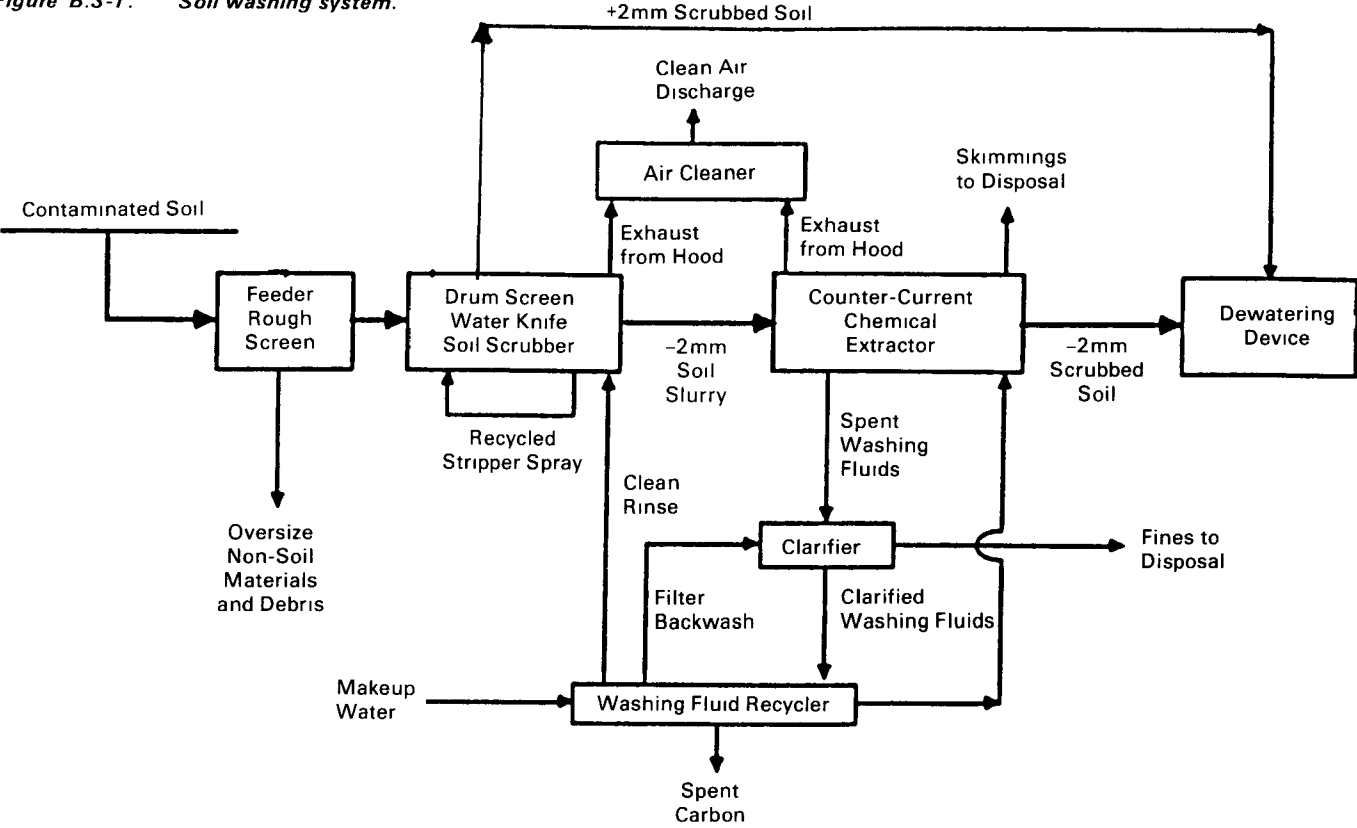

Source: EPA

Figure B.3-2. Soil washing.

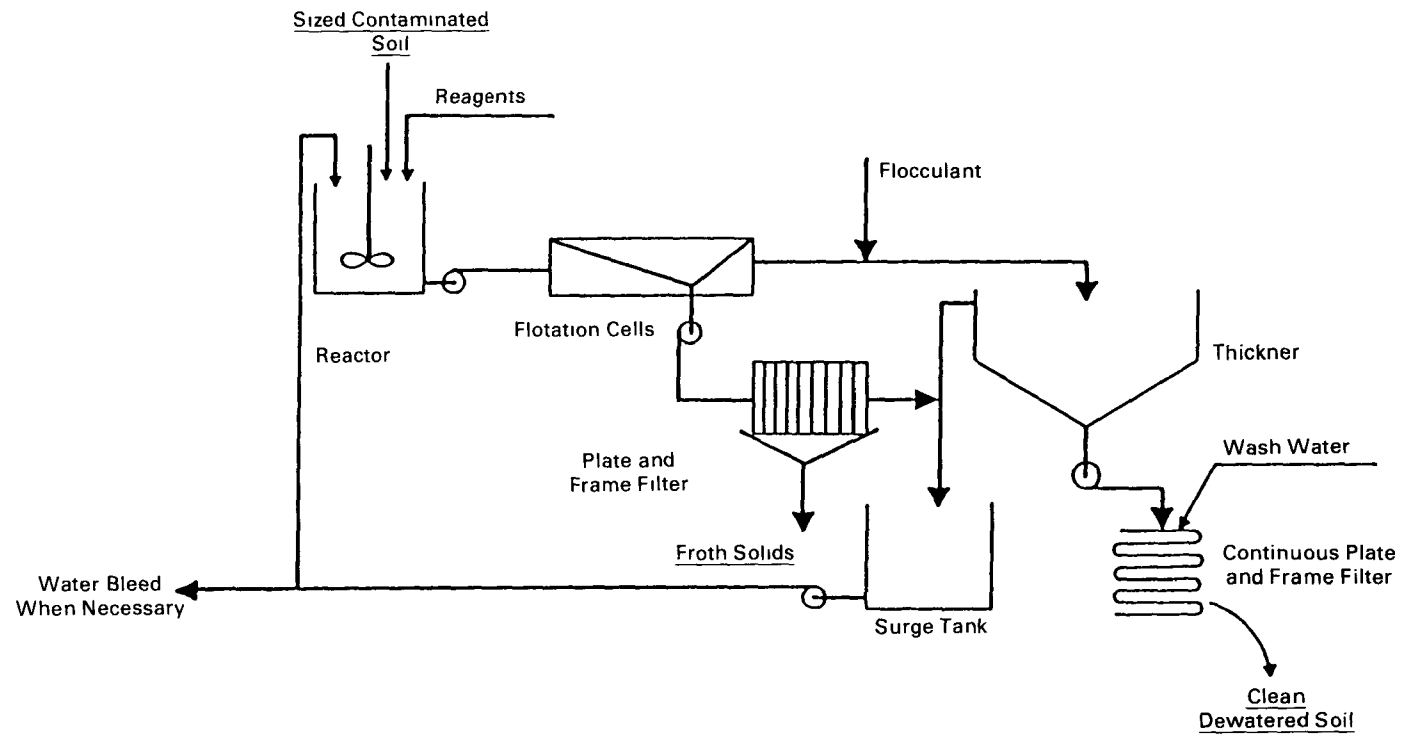

75

Source: MTARRI

Table B.3-1 Technology Summary.

Waste Type: Soils
Technology: Soil Washing

<i>Characteristics Impacting Process Feasibility</i>	<i>Reason for Potential Impact</i>	<i>Data Collection Requirements</i>	<i>Ref.</i>
<i>Unfavorable separation coefficient for contaminant</i>	<i>Excessive volumes of leaching medium required.</i>	<i>Equilibrium partition coefficient</i>	<i>1</i>
<i>Complex mixtures of waste types (e.g., metals with organics)</i>	<i>Formulation of suitable washing fluids difficult.</i>	<i>Analysis for priority pollutants, solubility data</i>	<i>2</i>
<i>Variation in waste composition</i>	<i>May require frequent reformulation of washing fluid.</i>	<i>Statistical sampling, analysis for priority pollutants</i>	<i>2</i>
<i>Unfavorable soil characteristics:</i>			
• <i>High humic content</i>	<i>Inhibition of desorption.</i>	<i>Analysis for organic matter</i>	<i>1,2, 3,4</i>
• <i>Soil, solvent reactions</i>	<i>May reduce contaminant mobility.</i>	<i>Pilot testing</i>	<i>1,2</i>
• <i>Fine particle size (silt and clay)</i>	<i>Fine particles difficult to remove from washing fluid.</i>	<i>Soil particle size distribution, USGS soil classification</i>	
• <i>Clay soil containing semivolatiles</i>	<i>Low recovery rate because organics are held more tenaciously.</i>		<i>**</i>
<i>Unfavorable washing fluid characteristics:</i>			
• <i>Difficult recovery of solvent or surfactant</i>	<i>High cost if recovery low.</i>	<i>Bench-scale testing</i>	<i>1</i>
• <i>Poor treatability of washing fluid</i>	<i>Requires replacement of washing fluid.</i>	<i>Bech-scale testing, conventional analysis*</i>	<i>1</i>
• <i>Reduction of soil permeability</i>	<i>Surfactant adheres to soil to reduce effective porosity.</i>	<i>Permeability pilot testing</i>	<i>1</i>
• <i>High toxicity of washing fluid</i>	<i>Soil may require additional treatment for detoxification. Fluid processing requires caution.</i>	<i>Toxicity of washing fluid</i>	<i>2</i>

* Conventional analysis should include organic content (e.g., BOD, COD, TOC), solids content, iron, manganese, and leachate pH.

** Information supplied by MTARRI .

B.4 In Situ Soil Flushing

Technology Description

In situ soil flushing, an active system, is a process applied to unexcavated soils using a ground water extraction/reinjection system. In situ soil flushing consists of injecting a solvent or surfactant solution (or water) to enhance the contaminant solubility, which results in increased recovery of contaminants in the leachate or ground water. The system includes extraction wells drilled in the contaminated soils zone, reinjection wells upgradient of the contaminated area, and a wastewater treatment system. The technology is often used for removal of volatile organics from permeable soils. More aggressive flushing involves ponds or sprinklers over the contaminated zone to accelerate migration of contaminants. The migration of contaminants into ground water must be prevented by incorporating proper control measures. Sandy soils may result in uncontrolled migration, and the inclusion of a clay-confining layer would be a desirable measure to control migration.

The technology includes extraction and treatment systems for contaminated ground water. Following treatment, the ground water is reinjected upgradient of the extraction wells and leaches through the contaminated soils. The leachate is then collected, treated, and re-injected back into the system, creating a closed loop system. Nontoxic or biodegradable surfactants or chelating agents may be added to the ground water prior to reinjection. The contaminated ground water is treated using various common wastewater techniques depending on the contaminant being removed. If surfactants or chelating agents that pose risks of additional contamination are added, they also must be removed for complete remediation. See Table 6 for further information on residuals management.

In situ soil flushing is both innovative and contaminant-specific. It has the greatest potential for success on soils contaminated with only a few specific chemicals. For soils and sludges that are contaminated with a variety of hazardous materials, the effectiveness is limited, and pretreatment or posttreatment may be necessary.

Status: Full-scale mobile units are currently available. This technology has been selected to decontaminate a CERCLA site, and the work will begin in 1988.

Figure B.4-1 illustrates in situ soil flushing, and Table B.4-1 is a technology restriction table.

EPA Contact:

Richard Traver, (201) 321-6677 FTS 340-6677
U.S. Environmental Protection Agency
Risk Reduction Engineering Laboratory
Edison, NJ 08837

Vendor:

Paul B. Trost, (303) 279-4255
MTA Remedial Resources, Inc.
1511 Washington Avenue
Golden, CO 80401

Al Bourquin, (206) 883-1900
Ecova Corporation
3820 159th Avenue NE
Redmond, WA 98052

Figure B.4-1 In situ soil flushing.

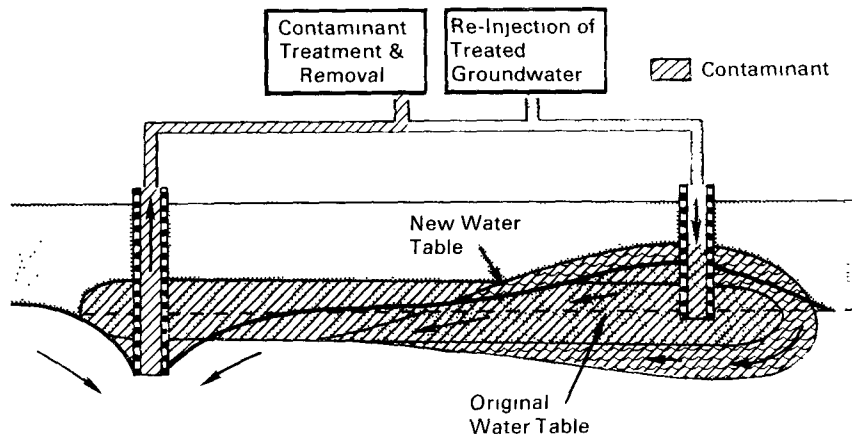

Source EPA/540/2-86/003(f)

Table B.4-1 Technology Summary.

Waste Type: Soils
Technology: In Situ Soil Flushing

<i>Characteristics Impacting Process Feasibility</i>	<i>Reason for Potential Impact</i>	<i>Data Collection Requirements</i>	<i>Ref.</i>
<i>Unfavorable separation coefficient for contaminant</i>	<i>Excessive volumes of surfactants required.</i>	<i>Equilibrium partition coefficient</i>	<i>1</i>
<i>Complex mixtures of waste types (e.g., metals with organics)</i>	<i>Formulation of suitable flushing fluids difficult</i>	<i>Analysis for priority pollutants, elemental analysis</i>	<i>2</i>
<i>Variation in waste composition</i>	<i>May require frequent reformulation of flushing fluid</i>	<i>Statistical sampling, analyses for priority pollutants</i>	<i>2</i>
<i>Unfavorable soil characteristics:</i>			
• <i>Variable soil conditions</i>	<i>Inconsistent flushing</i>	<i>Soil mapping</i>	<i>1,2</i>
• <i>High organic content</i>	<i>Inhibition of desorption.</i>	<i>Analysis for organic matter</i>	<i>1,2, 3,4</i>
• <i>Low permeability (high clay and/or silt content)</i>	<i>Reduces percolation.</i>	<i>Percolation test</i>	<i>2,3</i>
• <i>Soil, solvent reactions</i>	<i>May reduce contaminant mobility.</i>	<i>Pilot testing</i>	<i>1,2</i>
<i>Unfavorable site hydrology</i>	<i>Ground-water flow must permit recapture of flushed contaminants and, in some cases, soil-flushing fluids.</i>	<i>Site hydrogeology must be well defined</i>	<i>1,2</i>
<i>Unfavorable flushing fluid characteristics:</i>			
• <i>High toxicity or volatility</i>	<i>Health risks.</i>	<i>Surfactant characterization</i>	<i>1,2</i>
• <i>Difficult recovery of surfactant</i>	<i>High cost if recovery low.</i>	<i>Bench-scale testing</i>	<i>1</i>
• <i>Poor treatability of flushing fluid</i>	<i>Requires replacement of flushing fluid.</i>	<i>Bench-scale testing, conventional analysis*</i>	<i>1</i>
• <i>Reduction of soil permeability</i>	<i>Surfactant adheres to soil to reduce effective porosity.</i>	<i>Permeability pilot testing</i>	<i>1</i>

* *Conventional analysis should include organic content (e.g., BOD, COD, TOC), solids content, iron, manganese, and leachate pH.*

B.5 Glycolate Dechlorination

Technology Description

Potassium polyethylene glycolate (KPEG) dechlorination is an innovative process used to dehalogenate certain classes of chlorinated organics in contaminated organic liquids, sludges, and soils. For example, KPEG is used on waste oils containing dioxins and diesel fuel containing PCBs, dioxins, and chlorobenzenes, to convert them into lower toxicity, water-soluble materials. The KPEG solution reacts with the chlorinated organic and displaces a chlorine molecule. This technology, developed by General Electric, uses glycol reagent and has been demonstrated to destroy PCBs in contaminated soil to levels required by the regulation. The contaminated soils contained PCB in the range of <10 to 70/2 ppm, and the contamination was reduced to meet the regulatory standard in between 1.25 and 6.25 hours.

The process involves mixing equal portions of contaminated soil and KPEG reactants in a heated reactor. The slurry is then heated and mixed while the reaction occurs. The reaction time can range from 0.5 hour to up to 5 hours, depending on the type and concentration of the contaminants and the amount of dechlorination desired. The excess reagent is then decanted and the soil is washed two to three times with water to remove excess reagent and the products of the reaction. The decontaminated soil is then removed from the reactor. The decanted reagent and washes can be recycled to treat additional soil.

In the alkaline polyethylene glycolate (APEG) process developed by Galson Research Corporation, the reaction can be catalyzed by dimethyl sulfoxide (DMSO). The DMSO increases the rate of the reaction by increasing the alkalinity (i.e., strength) of the KPEG. The DMSO also aids in the extraction of the contaminant from the soil, thereby providing for better mixing of the reactants. The reagent and rinse waters are recycled.

Although KPEG reduces the toxicity of the waste, it increases the volume of waste that must be further treated as wastewater. Wastewaters containing reaction materials similar to those created as a residual by the KPEG process are commonly treated by chemical oxidation, biodegradation, carbon adsorption, or incineration. See Table 6 for further information on residuals treatment.

Status: A bench-scale unit was tested on PCB-contaminated soil during August 1987, a pilot-scale unit was tested in late 1987, and a full-scale unit is expected to be operational in 1988.

Figure B.5-1 illustrates the glycolate dechlorination process, and Table B.5-1 is a technology restriction table.

EPA Contact:

Charles J. Rogers, (513) 569-7757 FTS 684-7757
U.S. Environmental Protection Agency
Risk Reduction Engineering Laboratory
Cincinnati, OH 45268

Vendor:

Robert Peterson, Edwina Milicic, (315) 432-0506
Galson Research Corporation (APEG Process)
6601 Kirkville Road
E. Syracuse, NY 13057

Figure B.5-1. Glycolate dechlorination.

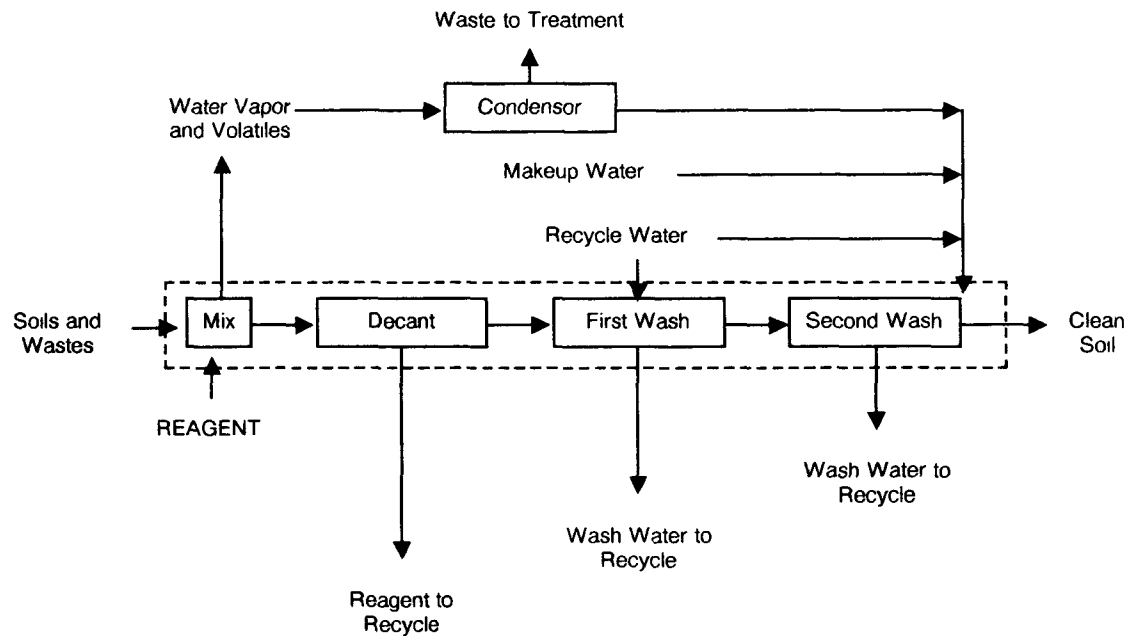

Source: Galson Research Corp.

Table B.5-1 Technology Summary.

Waste Type: Soils and Sludges
Technology: Glycolate Dechlorination

<i>Characteristics Impacting Process Feasibility</i>	<i>Reason for Potential Impact</i>	<i>Data Collection Requirements</i>	<i>Ref.</i>
<i>Elevated concentrations of chlorinated organics</i>	<i>Concentrations greater than 5% require excessive volumes of reagent. (Low ppm is optimum.)</i>	<i>Analysis for priority pollutants</i>	<i>5</i>
<i>Presence of:</i> <ul style="list-style-type: none"> ● <i>Aliphatic organics</i> ● <i>Inorganics</i> ● <i>Metals</i> 	<i>Reagent effective only with aromatic halides (PCBs, dioxins, chlorophenols, chlorobenzenes).</i>	<i>Analysis for priority pollutants</i>	<i>5</i>
<i>High moisture content (> 20%)</i>	<i>Water may require excessive volumes of reagent</i>	<i>Soil moisture content</i>	<i>5</i>
<i>Low pH (< 2)</i>	<i>Process operates under highly alkaline conditions.</i>	<i>pH testing</i>	<i>5</i>
<i>Presence of other alkaline reactive</i>	<i>Aluminum and possibly other metals that react under highly alkaline conditions may increase amount of reagent required by competing for the KPEG. The reaction may also produce hydrogen gas.</i>	<i>Metals analysis</i>	<i>5</i>
<i>High humic content in soil</i>	<i>Increases reaction time. Clay and sandy soils as well as high organic content soils can be treated with increased reaction time.</i>	<i>Organic content in soil</i>	<i>*</i>

* Information supplied by vendor.

B.6 Low Temperature Thermal Stripping

Technology Description

Ore design for a low temperature thermal stripping system processes contaminated soils through a pug mill or rotary drum system equipped with heat transfer surfaces. An induced airflow conveys the desorbed volatile organic/air mixture through a carbon adsorption unit or combustion afterburner for the destruction of the organics. The airstream is then discharged through a stack. These types of systems generally may be used to remove volatile organic compounds (Henry's Law constant $>3.0 \times 10^{-3}$ atm-m³/mole) from soils or similar solids. Process residuals are processed soil, ash from the afterburner or spent carbon, and stack gases. Chemical Waste Management has developed a mobile thermal desorption system called X*TRAXtm. This system employs a process in which solids with organic contamination are heated in the presence of water, driving off the water and organic contaminants and producing a dry solid containing trace amounts of the organic residue. The X*TRAX system consists of a dryer and an off-gas handling trailer. The dryer is a rotary kiln indirectly fired with propane as fuel. The contaminated solids or sludges are fed by auger or pump into the dryer and heated to 500-800°F. An inert nitrogen carrier gas transports the volatilized water and organics to the off-gas handling system, a three-stage cooling and condensing train which condenses organics of low, intermediate and high volatility in a stepwise fashion. The carrier gas is reheated and recirculated into the dryer. A small portion of carrier gas passes through a filter and a carbon adsorption drum before being vented to the atmosphere. The relatively low temperature heating in the presence of nitrogen prevents undesirable oxidation reactions.

The X*TRAX system is designed to treat solids or sludges containing organics with boiling points less than about 800°F, less than 10% total organics, and less than 60% moisture. For wastes that with higher organic or moisture levels, an economic evaluation is conducted to determine if the process is cost effective. Solid feeds must be screened to less than 1.25 inches in size, and for pumpable sludges, solids less than 0.4 inches must be removed.

Status: A pilot system constructed of off-the-shelf components has been tested on soils on at least one CERCLA site. The Chemical Waste Management System is to be tested on mixed hazardous and radioactive waste and PCB-contaminated soils in late 1988 and 1989.

Figure B.6-1 illustrates low temperature thermal stripping, and Table B.6-1 is a technology restriction table.

EPA Contact:

Robert Thurnau, (513) 569-7692, FTS 684-7692
Paul dePercin (513) 569-7797, FTS 684-7797
U.S. Environmental Protection Agency
Risk Reduction Engineering Laboratory
Cincinnati, OH 45268

Vendor:

Raja Venkateswar, (312) 841-8360
Chemical Waste Management, Incorporated
150 West 137th Street
Riverdale, IL 60627

Figure B.6-1 Low temperature thermal stripping.

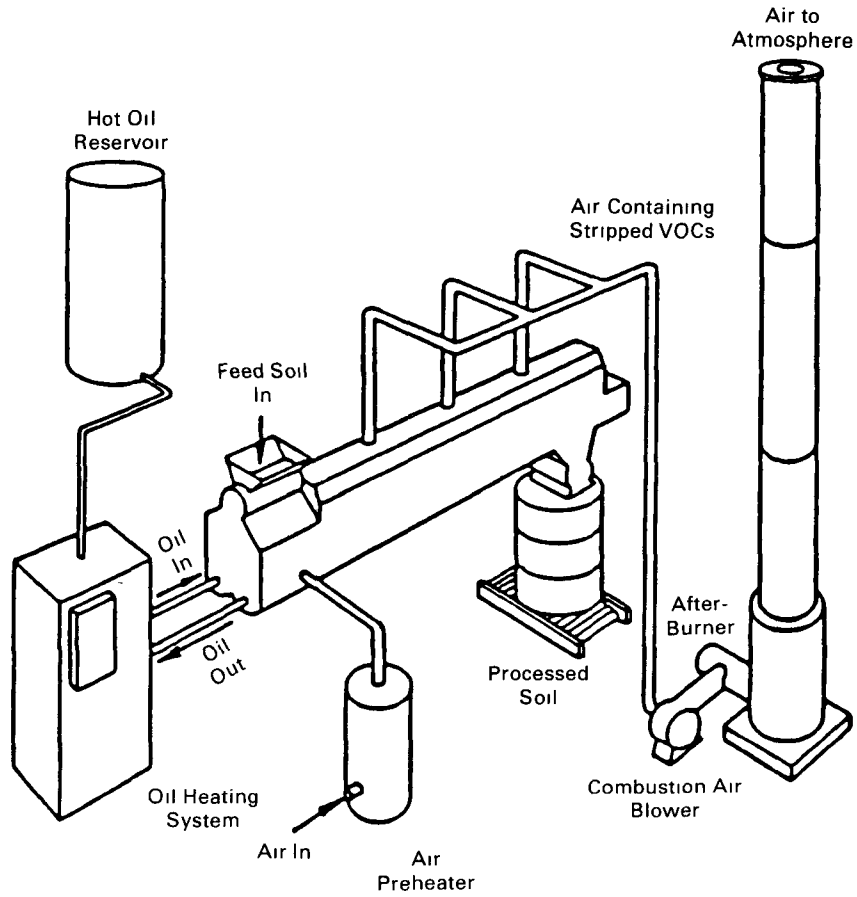

Source: U.S. Army Toxic and Hazardous Materials Agency, Aberdeen Proving Ground

Table B.6-1 Technology Summary.

Waste Type: Soils and Sludges
Technology: Low Temperature Thermal Stripping

<i>Characteristics Impacting Process Feasibility</i>	<i>Reason for Potential Impact</i>	<i>Data Collection Requirements</i>	<i>Ref.</i>
<i>Presence of:</i> <ul style="list-style-type: none"> ● <i>Metals</i> ● <i>Inorganics</i> ● <i>Less volatile organics</i> 	<i>Some process effective only for highly volatile organics (Henry's Law Constant > 3 x 10⁻³ atm-m³/mole). X*TRAX system can treat organics with boiling points up to about 800°F</i>	<i>Analysis for priority pollutants</i>	<i>2,**</i>
<i>pH <5, >11</i>	<i>Corrosive effect on system components</i>	<i>pH analysis</i>	<i>**</i>
<i>Presence of mercury (Hg)</i>	<i>Boiling point of mercury (356°C) close to operating temperature for process (100 to 300°C).</i>	<i>Analysis for mercury</i>	<i>2</i>
<i>Unfavorable soil characteristics:</i>			
<ul style="list-style-type: none"> ● <i>High percent of clay or silt</i> 	<i>Fugitive dust emissions during handling.*</i>	<i>Grain size analysis</i>	<i>6</i>
<ul style="list-style-type: none"> ● <i>Tightly aggregated soil or hardpan</i> 	<i>Incomplete devolatilization during heating.</i>	<i>Soil sampling and mapping</i>	<i>6</i>
<ul style="list-style-type: none"> ● <i>Rocky soil or glacial till</i> 	<i>Rock fragments interfere with processing.</i>	<i>Soil mapping</i>	<i>6</i>
<ul style="list-style-type: none"> ● <i>High moisture content</i> 	<i>High energy input required. Dewatering may be required as pretreatment.*</i>	<i>Soil moisture content</i>	<i>6</i>

* See Table 5.

** Information supplied by vendor

B.7 In Situ Vacuum and Steam Extraction

Technology Description

In situ vacuum extraction is a technology used to remove volatile (Henry's Law constant $>3 \times 10^{-3}$ atm-m/mole) organic compounds (VOCs) from soils. The basic components include production wells, monitoring wells, and high-vacuum pumps. The vacuum pumps are connected via a pipe system to a series of production wells. The production wells are drilled through the contaminated soil zone to just above the ground-water table. Spacing of the production wells is determined by mathematical models or pilot testing. Monitoring wells are drilled around the production wells to monitor the interstitial air pressure.

The system operates by applying a vacuum through the production wells. Once the wells are tightly sealed at the soil surface, a vacuum is created by the vacuum pumps. The vacuum is controlled by bleeding air into the system. Because of the pressure gradient created by the vacuum pumps, volatiles in the soil percolate and diffuse through the air spaces between the soil particles to the production wells. The vacuum established in the soil continuously draws VOC-contaminated air from the soil pores and draws fresh air from the soil surface down into the soil. The removed volatiles are processed through a liquid-vapor separator. The VOC vapors are then treated by an activated carbon bed, catalytic converter, or afterburner or are dispersed into the atmosphere. The liquid (VOC-contaminated ground water) is treated in a vacuum-assisted, fully enclosed aeration unit, which causes the VOCs to volatilize. The now gaseous VOCs are treated as above, and the ground water is discharged or reinjected into the ground. In most applications, the quantity of VOC-contaminated ground water extracted will be minimal. In areas with a high ground-water table, the VOC-contaminated air and ground water are removed simultaneously through the production wells without the need for additional pumps.

A similar system involves a series of air injection and air extraction wells. Fresh air is forced down the injection wells and VOC-contaminated air is withdrawn through the extraction wells. The removed VOC-contaminated air is then treated in a carbon adsorption unit.

Another technology, marketed under the trade name Detoxifier by Toxic Treatment (USA), Inc., uses a combination of drilling rig process tower, treatment agent, and delivery tool to remove petroleum and chlorinated hydrocarbons by steam stripping. The treatment system that has been demonstrated to treat volatile organics consists of two hollow blades that inject steam and hot air into the soil to a depth of almost 30 feet. The mixture heats the soil and raises the temperature of the chemicals, eventually causing them to evaporate. The evaporated chemicals are then trapped at the surface in a metal box and piped to a processor, which cools the chemical vapors until they turn into liquid. The liquid chemicals are taken to an incinerator. A technology known as the Geo-Con/DSM System can also be used to accomplish steam stripping of volatile organics (see B.2).

Status: Full-scale mobile units for vacuum and steam extraction are currently available and have been demonstrated on CERCLA wastes. Forced air injection units are currently being tested at pilot scale.

Figure B.7-1 illustrates in situ vacuum extraction, and Table B.7-1 is a technology restriction table. Figure B.2-1 is a process diagram that also applies to in situ steam extraction.

EPA Contact:

Mary Stinson, (201) 321-6683, FTS 340-6683
U.S. Environmental Protection Agency
Risk Reduction Engineering Laboratory
Edison, NJ 08837

Paul DePercin, (513) 569-7797, FTS 684-7797
U.S. Environmental Protection Agency
Risk Reduction Engineering Laboratory
Cincinnati, OH 45268

Vendors:

Jim Malot, (809) 723-9171
Terra Vac, Inc.
P.O. Box 1591
San Juan, PR 00903

Brian Jasperse, (412) 856-7700
Geo-Con Inc.
P.O. Box 17380
Pittsburgh, PA 15235

Michael Ridosh, (415) 572-2994
Toxic Treatment (USA) Inc.
901 Mariner's Island Blvd., Suite 315
San Mateo, CA 94404

Al Bourquin, (206) 883-1900
Ecova Corporation
3820 159th Avenue NE
Redmond, WA 98052

Figure B.7-1. In situ vacuum extraction.

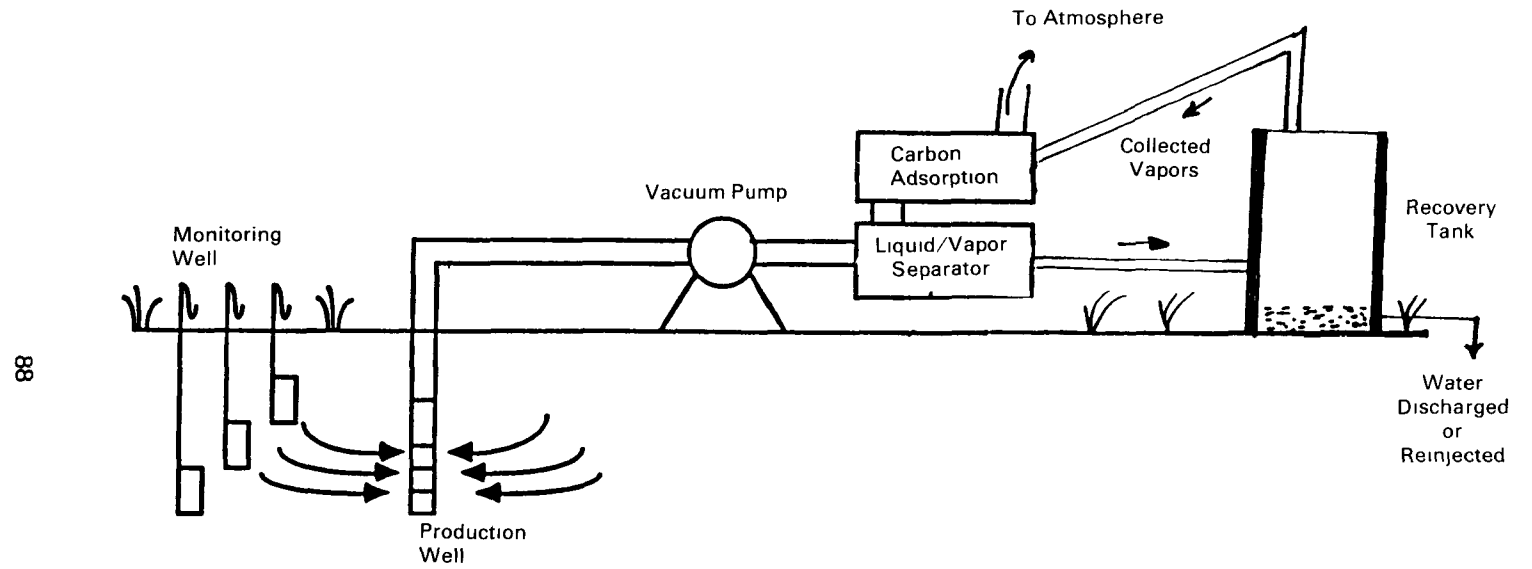

Source CDM

Table B.7-1 Technology Summary.

Waste Type: Soils
Technology: In Situ Vacuum and Steam Extraction

<i>Characteristics Impacting Process Feasibility</i>	<i>Reason for Potential Impact</i>	<i>Data Collection Requirements</i>	<i>Ref.</i>
Presence of: • Less volatile organics • Metals • Cyanides • Inorganics	Only volatile compounds with a Henry's Law constant of approximately $> 3 \times 10^{-3}$ atm-m ³ /mole can be effectively removed by vacuum extraction; theoretically, steam or hot air extraction should apply to less volatile compounds.	Analysis for priority pollutants, Henry's Law constant or vapor pressures for organics	8
High solubility of volatile organics in water	Dissolved organics are more mobile and harder to remove from aqueous phase.	Contaminant solubilities	8
Unfavorable soil characteristics:			
• Low permeability	Hinders movement of air through soil matrix.	Percolation test, pilot vapor extraction tests	7
• Variable soil conditions	Inconsistent removal rates.	Soil mapping	7
• High humic content	Inhibition of volatilization.	Analysis for organic matter	8
• High moisture content	Hinders movement of air through soil.	Analysis of soil moisture content	8

B.8 Stabilization/Solidification

Technology Description

Stabilization, also known as solidification or fixation, technology is applicable to solid, liquid, or sludge waste. Stabilization can be performed in situ or in tanks or containers. In situ stabilization is achieved by a deep soil mixing technique. In situ stabilization allows direct application of stabilizing agents, utilizing mixing paddles and augers that blend the soil with a stabilizing agent fed through the center of each shaft. At the end of the treatment, a treated block of soil or a continuous stabilized mass is left behind. Two in situ technologies marketed currently include Detoxifier and the Geo-Con/DSM System (see B.2).

Whether in ground or above ground in tanks, stabilization facilitates a chemical or physical reduction of the mobility of hazardous constituents. Organic oily wastes, sludges, and contaminated soil containing nonvolatile organics such as PCBs and creosote, and incinerator ash containing heavy metals may be treated successfully. Mobility is reduced through the binding of hazardous constituents into a solid mass with low permeability that resists leaching. The actual mechanism of binding, which depends on the type of stabilization process, can be categorized by the primary stabilizing agent used: cement-based, pozzolanic- or silicate-based, thermoplastic-based, or organic polymer-based. Techniques may overlap because additives, such as silicates, are frequently used in conjunction with the stabilizing agent to control curing rate or to enhance properties of the solid product.

On a commercial basis, organophilic proprietary compounds-based, asphalt-based, cement-based, and pozzolanic-based techniques have been more successful for treating hazardous wastes than the other techniques because of their wider range of applicability and less expensive reagents. Thus, the major focus of this discussion is on cement-based and pozzolanic-based techniques.

Stabilization technologies have been most widely successful when applied to inorganic waste streams. Before stabilization, the waste slurry or sludge may be pretreated to adjust pH and insolubilize heavy metals, thereby reducing their mobility. The high alkalinity of most cements and setting agents will serve to neutralize acidic leachate, keeping heavy metals in their insoluble, less mobile form.

Data suggest that silicates used with lime, cement, or other setting agents can stabilize a wider range of materials than cement-based technologies, including oily sludges and sludges and soils contaminated with solvents. Several vendors use organophilic proprietary compounds as additives to bind organics to the solid matrix. Both the cement-based and pozzolanic-based methods have been applied to radioactive wastes as well. The presence of solid organics such as plastics, resins, and tars often increases the durability of the solid end product.

The equipment used for container or tank stabilization is similar to the one used for cement mixing and handling. It includes a feed system, mixing vessels, and a curing area. Stabilization is applicable to many waste streams and waste matrices as well as contaminated soil because the mixing and handling techniques employed are very adaptive. Stabilization can be accomplished in situ using a lagoon or mixing pit. The existing lagoon may serve as mixing vessel, curing area, and final disposal site; or waste may be transferred to a mixing pit, which then serves as a curing area and possibly as a final disposal site. These techniques involve the use of common construction machinery such as a backhoe, pull shovel, or

front-end loader to mix the waste and reagents. Pumps can be used to transfer light sludge wastes to the mixing pits and pumpable uncured wastes to the curing site.

Critical parameters in stabilization treatment include selection of stabilizing agents and other additives, the waste-to-additive ratio, mixing, and curing conditions. All of these parameters are dependent on the chemical and physical characteristics of the waste. Bench-scale treatability tests should be conducted to select the proper additives and their ratios and to determine the curing time required to set the waste adequately. Leaching tests and compressive strength tests should be conducted to determine the integrity of the solid end product.

The short-term environmental impact of stabilizing most amenable wastes is small, but long-term reliability is not well known. Leachate that may be produced as a result of the curing process should be collected and analyzed to determine the necessity for treatment before disposal. The volume of leachate is usually minimal. Gas monitoring, collection, and treatment may be necessary with wastes containing ammonium ions or volatile organics. The alkalinity of cement drives off ammonium ion as ammonia gas. The heat generated by the curing or setting of the stabilized product can drive off organic volatiles. See Table 6 for further detail concerning residuals treatment.

Status: This technology has been commercially available for the treatment of RCRA and CERCLA wastes prior to landfilling. In situ stabilization has been used to treat CERCLA waste.

Figure B.8-1 illustrates stabilization/solidification, and Table B.8-1 is a technology restriction table. Figure B.2-1 illustrates the in-situ delivery technique.

EPA Contact:

Carlton Wiles, (513) 569-7795 FTS 684-7795
Edward Barth (513) 569-7669 FTS 684-7669
U.S. Environmental Protection Agency
Risk Reduction Engineering Laboratory
Cincinnati, OH 45268

Vendor:

This technology is readily available through numerous vendors.

Figure B.8-1 Stabilization/solidification.

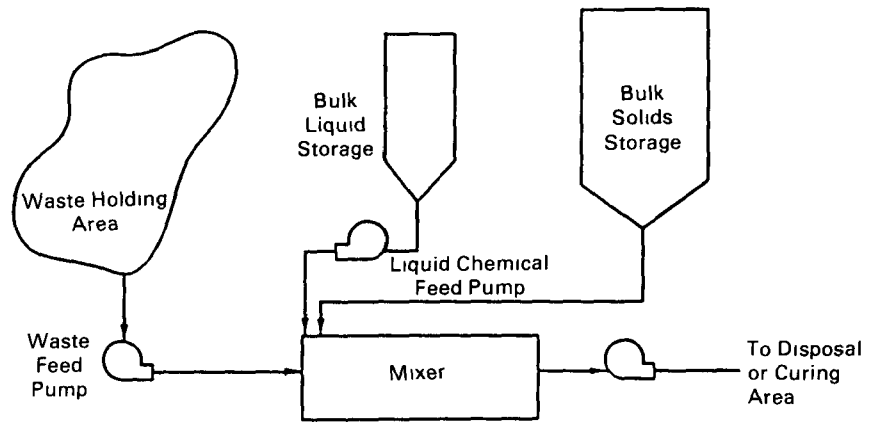

Source: EPA

Table B.8-1 Technology Summary.

Waste Type: Soils and Sludges
Technology: Stabilization/Solidification

<i>Characteristics Impacting Process Feasibility</i>	<i>Reason for Potential Impact</i>	<i>Data Collection Requirements</i>	<i>Ref.</i>
<i>Organic content should be no greater than 20-45% by weight when using cement-based technologies</i>	<i>Organics interfere with bonding of waste materials.</i>	<i>Analysis for volatile solids, total organic carbon</i>	<i>2,10</i>
<i>Semivolatile organics > 10,000 ppm PAHs > 10,000 ppm</i>	<i>Organics interfere with bonding of waste materials</i>	<i>Analysis for semivolatile organics, PAHs</i>	<i>*</i>
<i>Wastes with less than 15% solids</i>	<i>Large volumes of cement or other reagents required, greatly increasing the volume and weight of the end product. Waste may require reconstitution with water to prepare waste/reagent mix.</i>	<i>Analysis for total solids and suspended solids</i>	<i>2</i>
<i>Oil and grease should be < 10%* when using cement-based technology</i>	<i>Weaken bonds between waste particles and cement by coating the particles.</i>	<i>Analysis for oil and grease</i>	<i>2</i>
<i>Fine particle size</i>	<i>Insoluble material passing through a No. 200 mesh sieve can delay setting and curing. Small particles can also coat larger particles, weakening bonds between particles and cement or other reagents. Particle size > 1/4 inch in diameter not suitable.</i>	<i>Soil particle size distribution</i>	<i>2</i>
<i>Halides</i>	<i>May retard setting easily leached</i>	<i>Analysis for total halides</i>	<i>9</i>
<i>Soluble salts of manganese, tin, zinc, copper, and lead</i>	<i>Reduce physical strength of final product; cause large variations in setting time; reduce dimensional stability of the cured matrix, thereby increasing leachability potential.</i>	<i>Analysis for inorganic salts</i>	<i>2,10</i>
<i>Cyanides > 3,000 ppm</i>	<i>Cyanides interfere with bonding of waste materials</i>	<i>Analysis for cyanides</i>	<i>*</i>

* Information provided by vendors marketing this technology.

Table B.8-1 Technology Summary (continued).

Waste Type: Soils and Sludges
Technology: Stabilization/Solidification

<i>Characteristics Impacting Process Feasibility</i>	<i>Reason for Potential Impact</i>	<i>Data Collection Requirements</i>	<i>Ref.</i>
<i>Sodium arsenate, borates, phosphates, iodates, sulfide, and carbohydrates</i>	<i>Retard setting and curing and weaken strength of final product.</i>	<i>Bench-scale testing</i>	<i>2,10</i>
<i>Sulfates</i>	<i>Retard setting and cause swelling and spalling.</i>	<i>Analysis for sulfate</i>	<i>2,8</i>
<i>Volatile organics</i>	<i>Volatiles not effectively immobilized. Driven off by heat of reaction.</i> <i>Sludges containing volatile organics can be treated using a heated extruder/evaporator to evaporate free water and VOCs and mixing with asphalt. VOCs with flashpoint below 350°F, thermally unstable materials, solvents in sufficient concentrations to soften the asphalt, and highly reactive materials require pretreatment.</i>	<i>Analysis for volatile organics, bench-scale testing</i>	<i>9</i> <i>*</i>
<i>Presence of leachable metals</i>	<i>Effectiveness of stabilization methods may vary.</i>	<i>Analysis for priority pollutants, bench-scale testing</i>	<i>10</i>
<i>Phenol concentration greater than 5%</i>	<i>Results in marked decreases in compressive strength.</i>	<i>Analysis for phenols</i>	<i>5,9</i>
<i>Presence of coal or lignite</i>	<i>Coals and lignite can cause problems with setting, curing, and strength of the end product.</i>	<i>Core sampling with specific analysis for coal.</i>	<i>8</i>

** Information provided by vendors marketing this technology.*

B.9 Chemical Reduction-Oxidation

Technology Description

The chemical reduction-oxidation (redox) process is employed to destroy hazardous components or convert the hazardous components of the waste stream to less hazardous forms. Redox processes are based on reduction-oxidation reactions between the waste components and added reactants in which the oxidation state of one reactant is raised while that of another is lowered.

A significant use of chemical redox is the reduction of hexavalent chromium (Cr^{+6}) to trivalent chromium (Cr^{+3}), which is less toxic and more susceptible to chemical precipitation. Redox has also been used to treat mercury-, silver-, and lead-contaminated wastes. Common reducing agents include alkali metals (sodium, potassium) sulfur dioxide, sulfite salts, ferrous sulfate, iron, aluminum, zinc, and sodium borohydrides.

Chemical oxidation is used primarily for treatment of cyanide and dilute waste streams containing oxidizable organics. Among the organics for which oxidative treatment has been reported are aldehyde, mercaptans, phenols, benzidine, unsaturated acids, and certain pesticides. Common commercially available oxidants include potassium permanganate, hydrogen peroxide, hypochlorite, and chlorine gas.

The chemical redox treatment process consists of initial pH adjustment, addition of redox reagents, mixing, and treatment to remove or precipitate the reduced or oxidized products. Chemical redox has limited application to sludges because of difficulties in achieving intimate contact between the reagent and the hazardous constituent. Sludges must be slurried prior to treatment to achieve a suspended solids content of 3 percent or less. Chemical redox is not well suited for high-strength, complex waste streams. The most powerful oxidants and reductants are relatively nonselective, and any oxidizable/reducible constituents in the waste may be treated. For highly concentrated waste streams this will result in the need to add large concentrations of reagent to treat target compounds.

The chemical redox process generates a solids/liquids effluent that requires further treatment. If the reduced hazardous components are still in a soluble form under system conditions, chemical precipitation methods must be employed to convert these components to an insoluble form. Following reduction and/or precipitation, the solids must be separated from the liquid by filtration, settling, or evaporation. Chemical oxidation reactions with organics are frequently incomplete, requiring biological or carbon adsorption post treatment. When using the chemical reduction-oxidation technique for treating chlorinated organics, a possibility of producing HCl exists. Leach tests should be conducted on the residual solids to determine the need for stabilization before final disposal. The liquid effluent should be analyzed before discharge to ensure regulatory compliance.

Wastes that can be treated via redox include: (a) benzene, phenols, most organics, cyanide, arsenic, iron, and manganese (oxidation treatment) and (b) chromium (VI), mercury, lead, silver, chlorinated organics like PCBs, and unsaturated hydrocarbons (reduction treatment).

Status: This technology is widely available for RCRA wastes and is potentially applicable to a variety of CERCLA wastes.

Figure B.9-1 illustrates the chemical reduction-oxidation process, and Table B.9-1 is a technology restriction table.

EPA Contact:
Charles J. Rogers, (513) 569-7757, FTS 684-7757
U.S. Environmental Protection Agency
Risk Reduction Engineering Laboratory
Cincinnati, OH 45268

Vendor:
No specific names of vendors are listed
here since the technology is widely available

Figure B.9-1 Chemical reduction/oxidation.

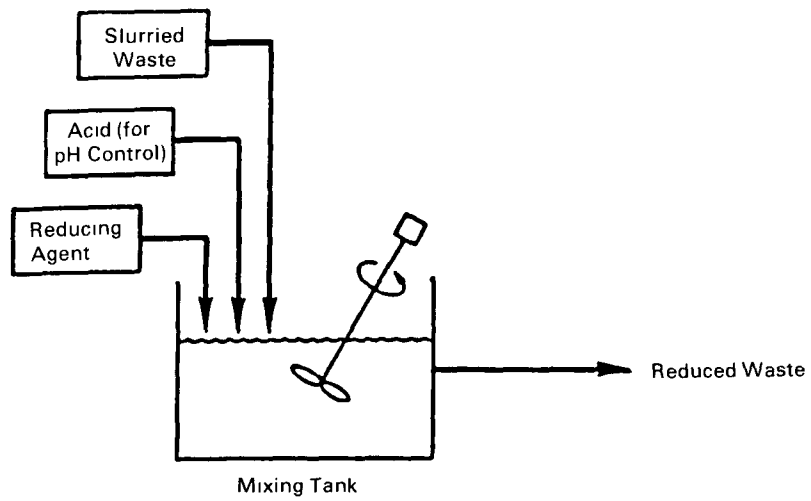

Table B.9-1 Technology Summary.

Waste Type: Sludges
Technology: Chemical Reduction/Oxidation

<i>Waste Characteristics Impacting Process Feasibility</i>	<i>Reason for Potential Impact</i>	<i>Data Collection Requirements</i>	<i>Ref.</i>
<i>Organic content</i>	<i>Oxidizable organics in the sludge will create competing redox reactions, therefore requiring larger amounts of oxidation/reduction reagent.</i>	<i>Analysis for priority pollutants, chemical oxygen demand (COD) analysis</i>	<i>10</i>
<i>Variation in waste composition</i>	<i>Chemical redox is indiscriminate; unwanted side reactions could occur.</i>	<i>Statistical sampling, priority pollutant analysis</i>	<i>2,3</i>
<i>Chromium (+3), mercury, lead, silver</i>	<i>Oxidation of organic sludges will oxidize these metals to their more toxic and mobile forms.</i>	<i>Analysis for total chromium, mercury, and silver</i>	<i>3</i>
<i>High viscosity</i>	<i>Subsequent need for addition of liquid to aid mixing.</i>	<i>Bench-scale testing</i>	<i>4</i>
<i>Low pH of sludge</i>	<i>A low pH (<2) may interfere with redox reagents.</i>	<i>pH testing</i>	<i>4</i>
<i>Oil and grease content</i>	<i>Oil and grease content of greater than 1% by weight interferes with reactant/waste contact.</i>	<i>Analysis for oil and grease</i>	<i>11</i>
<i>Suspended solids content</i>	<i>A suspended solids content of greater than 3% by weight can interfere with reductant/waste contact inhibiting reduction. Sludges therefore will need to be slurried prior to treatment.*</i>	<i>Total suspended solids</i>	<i>11</i>

* See Table 4.

B.10 In Situ Vitrification

Technology Description

In situ vitrification (ISV) is the process of melting wastes and soils or sludges in place to bind the waste in a glassy, solid matrix resistant to leaching and more durable than granite or marble. ISV technology is based on the concept of joule-heating to electrically melt soil or sludge. Melt temperatures are in the range of 1600 to 2000°C and act to destroy organic pollutants by pyrolysis. Although the process was initially developed to provide enhanced isolation to previously disposed radioactive wastes, the process may also destroy or immobilize many inorganic and organic hazardous chemical wastes. There are several general areas where the ISV process might be applied to hazardous waste: contaminated soil sites, burial grounds, tanks that contain a hazardous heel in the form of either a sludge or a salt cake, and process sludges.

In the ISV process, four electrodes are inserted into the soil to the desired treatment depth. A conductive mixture of flaked graphite and glass frit is usually placed among the electrodes to act as the starter path for the electrical circuit. Heat from the high current of electricity passing through the electrodes and graphite creates a melt. The graphite starter path is eventually consumed by oxidation, and the current is transferred to the molten soil, which is now electrically conductive. As the melt grows downward and outward, it incorporates nonvolatile elements and destroys organic components by pyrolysis. The pyrolyzed byproducts migrate to the surface of the vitrified zone, where they combust in the presence of oxygen. Inorganic materials are dissolved into or are encapsulated in the vitrified mass. Convective currents within the melt uniformly mix materials that are present in the soil. When the electric current ceases, the molten volume cools and solidifies. A hood placed over the processing area provides confinement for the combustion gases, drawing the gases into an off-gas treatment system.

Specific site characteristics must be considered in determining the applicability of ISV. In the event that feasibility tests indicate problems in soil conductance or vitrification, sand, soda ash, or glass frit can be mixed with the soil to improve the process. A combination of high soil permeability and the presence of ground water can create economic limitations to the process. The process will work with fully saturated soils; however, the water in the soil must be evaporated before the soil will begin to melt. If the soil moisture is being recharged by an aquifer, there is an additional economic impact. Soils with permeabilities higher than 10^{-4} cm/sec are difficult to vitrify in the presence of flowing ground water and therefore require temporary ground-water diversion, if practical, during processing. If buried metals, such as drums, occupy over 90 percent of the linear distance between electrodes, a conduction path that leads to electrical shorting between electrodes may result.

The environmental impact of the off-gas must also be addressed when considering ISV. A hood must be placed over the processing area to collect volatiles driven off during startup, combustion gases, and steam and convey them into the off-gas treatment system. The depth of inorganics, such as cadmium or lead, has a direct effect on the retention of the inorganic in the melt. The presence of combustibles can provide a path to the surface by entraining heavy metal oxides in the combustion product gases. The closer they are to the surface, the more likely it is that the entrained materials will not be removed and recaptured by the melt or recaptured in the off-gas treatment system. Individual applications must

be reviewed in detail prior to making final applicability decisions. Small-scale feasibility tests and detailed site mapping are of vital importance. By-products of the process include an aqueous scrub solution. When scrub solution contains low levels of contaminants, residual treatment may be required. See Table 6 for more detail on residuals treatment.

Figure B.10-1 illustrates the in situ vitrification process, and Table B.10-1 is a technology restriction table.

EPA Contact:

Jonathan Herrmann, (513) 569-7839 FTS 684-7839
U.S. Environmental Protection Agency
Risk Reduction Engineering Laboratory
Cincinnati, OH 45268

Vendor:

James Hansen, (206) 822-4000
GeoSafe Corporation
303 Parkplace Suite 126
Kirkland, WA 98033

Figure B.10-1. In situ vitrification.

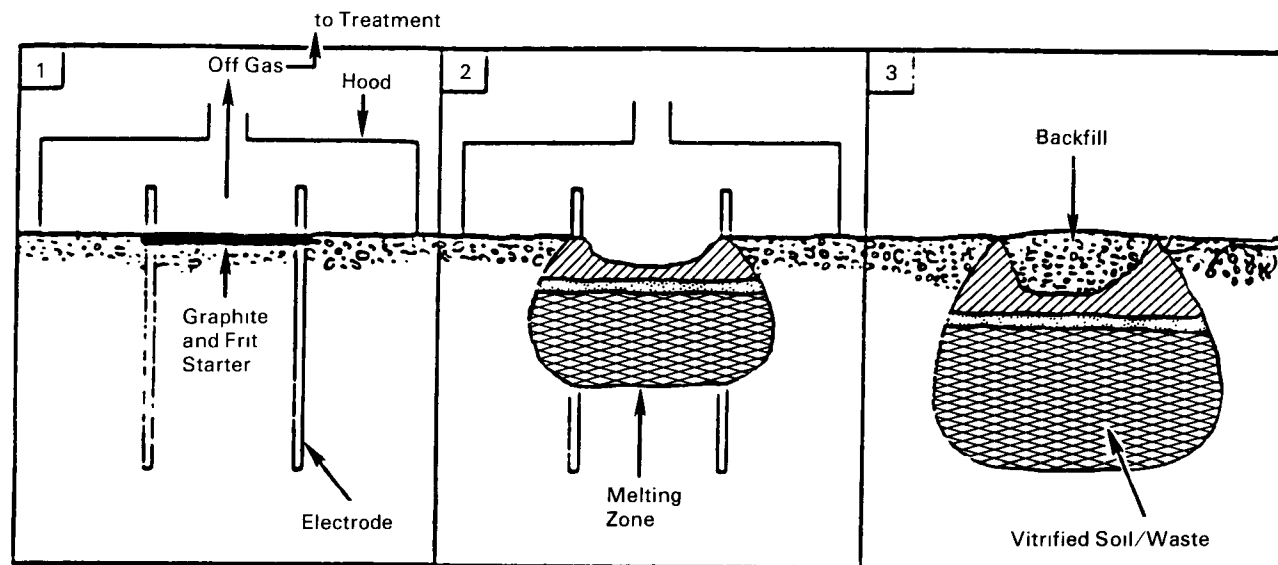

Source: Battelle Pacific Northeast Laboratories

Table B.10-1 Technology Summary.

Waste Type: Soils and Sludges
Technology: In Situ Vitrification

<i>Characteristics Impacting Process Feasibility</i>	<i>Reason for Potential Impact</i>	<i>Data Collection Requirements</i>	<i>Ref.</i>
<i>Presence of ground water and soil permeability less than 1×10^{-5} cm/sec</i>	<i>Severely limits economic practicality because much energy will be expended in driving off water.</i>	<i>Percolation test/water table mapping</i>	<i>12</i>
<i>Buried metals (drums) occupying over 90% of linear distance between electrodes</i>	<i>Buried metals can result in a conductive path that would lead to electrical shorting between electrodes.</i>	<i>Site mapping</i>	<i>12</i>
<i>Loosely packed rubbish, buried coal</i>	<i>May start underground fire.</i>	<i>Site mapping</i>	<i>™</i>
<i>Combustible liquids* (9600 lb/yd of depth or 7 wt %)</i>	<i>Time-ordered limits to the capacity of the off-gas system to contain combustion gas. Not cumulative capacity.</i>	<i>Site mapping, analysis for priority pollutants, feasibility testing</i>	<i>12</i>
<i>Combustible solids* (6400 lb/yd of depth or 4.7 wt %, including 30% soil with the solids)</i>	<i>Time-ordered limits to the capacity of the off-gas system to contain combustion gas. Not cumulative capacity.</i>	<i>Site mapping, analysis for priority pollutants, feasibility testing</i>	<i>12</i>
<i>Combustible packages* (1.2 yd³ or 32 ft³)</i>	<i>Time-ordered limits to the capacity of the off-gas system to contain combustion gas. Not cumulative capacity.</i>	<i>Site mapping, analysis for priority pollutants, feasibility testing</i>	<i>12</i>
<i>Volatile metal content and depth</i>	<i>Retention of volatile metals in melt is reduced as surface is approached. Clean soil may be placed on top to increase depth to which off-gas treatment may be relied on.</i>	<i>Site mapping, analysis for Cd, Pb, Hg, As</i>	<i>12</i>
<i>Combustible liquids</i>	<i>9600 lb/yd of depth or 7% by weight.</i>		<i>™</i>
<i>Void volumes</i>	<i>5-6 yd³ or 152 ft³.</i>		<i>™</i>

* Concentration limits are generic in nature; individual applications need to be reviewed in detail.

™ Vendor information sheet.

References

- (1) In situ flushing and soils washing technologies for Superfund sites. 1985. Presented at RCRA/Superfund Engineering Technology Transfer Symposium by Risk Reduction Engineering Laboratory, U.S. Environmental Protection Agency, Cincinnati, Ohio.
- (2) USEPA. 1986. U.S. Environmental Protection Agency, Office of Solid Waste and Emergency Response. *Mobile treatment technologies for Superfund wastes*. #540/2-86/003(f). Washington, D.C.: U.S. Environmental Protection Agency.
- (3) Akers, C.K., Pilie, R.J., and Michalouic, J.G. 1981. *Guidelines for the use of chemicals in removing hazardous substance discharges*. EPA - 600/52-81-25.
- (4) Ellis, W.D., and Payne, J.R. The development of chemical countermeasures for hazardous waste contaminated soil. Edison, N.J.: Oil and Hazardous Materials Spills Branch, U.S. Environmental Protection Agency.
- (5) Cullinane, M.J., Jr., Bricka, R.M., and Francingues, N.R., Jr. 1987. An assessment of materials that interfere with stabilization/solidification processes. In *land Disposal, Remedial Action, Incineration, and Treatment of Hazardous Waste, Proceedings of the Thirteenth Annual Research Symposium*. Cincinnati, Ohio: U.S. Environmental Protection Agency, Risk Reduction Engineering Laboratory.
- (6) Noland, N.W., McDevitt, N., and Koltuniak, D. 1985. Low temperature thermal stripping of volatile organic compounds from soils. Edgewood, Maryland: U.S. Army Toxic and Hazardous Materials Agency, Aberdeen Proving Ground.
- (7) Malot, J. 1985. Vacuum extraction of VOC contamination in soils. Dorado, Puerto Rico: Terra Vac, Inc.
- (8) USEPA. 1985. U.S. Environmental Protection Agency, Office of Research and Development. *1985 handbook - remedial action at waste disposal sites*. Risk Reduction Engineering Laboratory, Office of Research and Development. #625-6-85-006. Cincinnati, Ohio: U.S. Environmental Protection Agency.
- (9) Cullinane, M., Jr., Jones, L.W., and Malone, P.G. 1986. *Handbook for stabilization/solidification of hazardous waste*. Cincinnati, Ohio: U.S. Environmental Protection Agency, Risk Reduction Engineering Laboratory.
- (10) USEPA. 1979. U.S. Environmental Protection Agency. Survey of solidification/stabilization technology for hazardous industrial waste by environmental laboratory - U.S. Army Engineer Waterways Experiment Station, Vicksburg, Miss. #600/2-79-056.
- (11) Versar Inc. 1985. Assessment of treatment technologies for hazardous waste and their restrictive waste characteristics. Vol. 1A-D. Washington, D.C.: U.S. Environmental Protection Agency, Office of Solid Waste.
- (12) Fitzpatrick, V.F., Timmerman, C.L., and Buelt, J.L. 1986. In-situ vitrification - a candidate process for in-situ destruction of hazardous waste. Presented at the Seventh Superfund Conference, Washington, D.C., December 1-3, 1986. Richland, Washington: Pacific Northwest Laboratory.

Appendix C

Biological Treatment Technologies

Introduction

Several well-developed biological technologies exist for the treatment of aqueous waste streams contaminated at various levels with nonhalogenated organics and some halogenated organics. The subject of this appendix, however, is the biodegradation of organic contaminants in sludges and soils. Contaminated sludges and soils can be biologically treated in situ or excavated and treated by solid-phase and slurry-phase bioremediation processes. Solid-phase and slurry-phase processes are being developed, and in some cases have been used, to treat a wide range of contaminants such as pesticides, diesel, gasoline, fuel oil, creosote, pentachlorophenol, and halogenated volatile organics. Enhanced in situ biodegradation is being used for sites having soil and ground water contaminated with readily biodegradable organics such as gasoline and diesel. This technology is being developed for contaminants that are more difficult to degrade.

This appendix contains information on biological treatment technologies. For each technology, a technology description is provided, followed by an illustration of the process and a technology restriction table. Each technology restriction table includes a listing of the characteristics impacting the feasibility of the process, reasons for restriction, data collection requirements, and references. The numbers in the "Reference" column are correlated with the list of references included at the end of this appendix.

C.1 Biodegradation

Technology Description

Biodegradation is the bio-oxidation of organic matter by microorganisms. Composting, in situ biodegradation, solid-phase and slurry-phase treatment are four biodegradation techniques applicable to soils and sludges. In situ biodegradation is discussed separately.

C.1.1 Composting

Composting involves the storage of highly biodegradable and structurally firm material (e.g., chopped hay, wood chips, etc.) with a small percentage (<10%) biodegradable waste. Composting is enhanced by waste size uniformity. Adequate aeration, optimum temperature, moisture and nutrient contents, and the presence of an appropriate microbial population are necessary to enhance decomposition of organic compounds.

There are three basic types of composting: open windrow systems, static windrow systems, and in-vessel (reactor) systems. The open windrow system consists of stacking the compost into elongated piles. Aeration is accomplished by tearing down and rebuilding the piles. The static windrow system also involves long piles of compost. However, the piles are aerated by a forced air system; i.e., the piles are built on top of a grid of perforated pipes. Finally, the in-vessel system involves placing the compost into an enclosed reactor. Aeration is accomplished by tumbling, stirring, and forced aeration.

In general, compared to in situ biodegradation, composting is relatively insensitive to toxicants. The optimum temperature range for composting is between 10 and 45°C or between 50 and 70°C.

When treating CERCLA wastes, it is necessary to collect leachate and runoff water from the composting beds. See Table 6 for information on residuals management.

Composting has not been widely used but is potentially applicable to both sludges and soils.

C.1.2 Slurry-Phase Treatment

A second biodegradation technology involves the treatment of contaminated soil or sludge in a large mobile bioreactor. This system maintains intimate mixing and contact of microorganisms with the hazardous compounds and creates the appropriate environmental conditions for optimizing microbial biodegradation of target contaminants.

The first step in the treatment process is to create the aqueous slurry. During this step stones and rubble are physically separated from the waste, and the waste is mixed with water, if necessary, to obtain the appropriate slurry density. The water may be contaminated ground water, surface water, or another source of water. A typical soil slurry contains about 50 percent solids by weight; a slurried sludge may contain fewer solids. The actual percent solids is determined in the laboratory based on the concentration of contaminants, the rate of biodegradation, and the physical nature of the waste. The slurry is mechanically agitated in a reactor vessel to keep the solids suspended and maintain the appropriate environmental conditions. Inorganic and organic nutrients, oxygen, and acid or alkali for pH control may be added to maintain optimum conditions. Microorganisms may be added initially to seed the bioreactor or added continuously to maintain the correct concentration of biomass. The residence time in the bioreactor varies with the soil or sludge matrix, physical/chemical nature of

the contaminant, including concentration, and the biodegradability of the contaminants. Once biodegradation of the contaminants is completed, the treated slurry is dewatered. The residual water may require further treatment prior to disposal.

Depending on the nature and concentration of the contaminants, and the location of the site, any emissions may be released to the atmosphere, or treated to prevent emission. Fugitive emissions of volatile organic compounds, for instance, can be controlled by modifying the slurry-phase bioreactor so that it is completely enclosed. See Table 6 for information on residuals management.

Aside from the biodegradability of a particular compound, other limiting factors include the presence of inhibiting compounds and operating temperature. Heavy metals and chlorides may inhibit microbial metabolism because of their toxicity. The operating temperature range is approximately 15–70°C. Dissolved oxygen is also critical and must be monitored along with pH, nutrients, and waste solubility.

One advantage of treatment in a contained process is that a remediation system can be designed to pretreat waste contaminated with heavy metals as well as biodegradable semi-volatile and volatile compounds. Soil washing and extraction of metals using weak acids and chelating agents can be combined with biological treatment by coupling two separate slurry-phase reactors in series.

Several firms market slurry-phase biological treatment systems. Ecova Corporation markets slurry-phase treatment for highly-contaminated soils (e.g., up to 14,000 ppm pesticides). Ecova can combine their biological system with several other processes to handle vapors and heavy metals. Ecova's system removes debris greater than 0.25 inches in diameter prior to transferring to the bioreactor.

Detox Industries uses a slurry-phase biological treatment system to biodegrade chlorinated hydrocarbons with naturally occurring microorganisms. Detox claims that the process is particularly suited to degradation of PCBs in soil and in sludges.

MoTec calls its slurry-phase system liquid-solid contact digestion. They specialize in treating soil and sludge contaminated with creosote and pentachlorophenol but are also studying the application of their system to other types of biodegradable waste. This system requires co-metabolites which provide carbon and hydrogen that can be easily digested by the microorganisms. Once the co-metabolites such as polynuclear aromatics, chlorinated hydrocarbons, or chlorinated aromatics are consumed, the bacteria begin to metabolize target molecules in the waste that resemble the co-metabolites. After completion of treatment, the solids are allowed to settle, and the water is decanted. The sludge is then air-dried, and the water is treated.

C.1.3 Solid-Phase Treatment

Solid-phase soil bioremediation is a process that treats soils in an above grade system using conventional soil management practices to enhance the microbial degradation of contaminants. The system can be designed to contain and treat soil leachate and volatile organic compounds.

A system used by Ecova consists of a treatment bed which is lined with an 80-millimeter high-density liner with heat-welded seams. Clean sand is placed on top of the line to provide protection for the liner and proper drainage for contaminated water as it leaches from contaminated soils placed on the treatment bed. Lateral perforated drainage pipe is placed on

top of the synthetic liner in the sand bed to collect soil leachate. If volatile contaminants must be contained, the lined soil treatment bed is completely covered by a modified plastic film greenhouse. An overhead spray irrigation system contained within the greenhouse provides for moisture control and a means of distributing nutrients and microbial inocula to the soil treatment bed.

Volatile organic compounds which may be released from the soil during processing are swept through the structure to an air management system. Biodegradable volatile organic compounds can be treated in a vapor phase bioreactor. Non-biodegradable volatile organic compounds can be removed from the effluent gas stream by adsorption on activated carbon or incineration.

Contaminated leachate which drains from the soil is transported by the drain pipes and collected in a gravity-flow lined sump and then pumped to an on-site bioreactor for treatment. Treated leachate can then be used as a source of microbial inocula and reapplied to the soil treatment bed through an overhead irrigation system, after adjusting for nutrients and other environmental parameters.

Status: The MoTec technology has been used to treat pentachlorophenol and creosote wastes, oil field and refinery sludges, and pesticide wastewaters. The Detox process has been used to treat wastes containing PCBs and pentachlorophenol. Ecova has applied slurry-phase bioremediation at the full scale to soil containing pesticides and diesel fuel, and at the pilot scale to soil contaminated with polyaromatic hydrocarbons (PAHs). Ecova has used solid-phase biodegradation at full scale to treat soil containing gasoline, pesticides, and a mixture of motor oil and diesel, and at the pilot scale to soils containing PAHs and pentachlorophenol.

Figure C.1-1 illustrates the slurry-phase biodegradation process, Figure C.1-2 illustrates the solid-phase biodegradation system, and Table C.1-1 is a technology restriction table.

EPA Contact:

Ronald Lewis, (513) 569-7856, FTS 684-7856
Eugene Harris, (513) 569-7862, FTS 684-7862
U.S. Environmental Protection Agency
Risk Reduction Engineering Laboratory
Cincinnati, OH 45268

Vendors:

Tom Dardas, (713) 240-0892
Detox Industries, Inc.
12919 Dairy Ashford
Sugarland, TX

John Bogart, (615) 754-9626
MoTec, Inc.
P.O. Box 338
Mt. Juliet, TN 37122-0338

Al Bourquin, (206) 883-1900
Derek Ross (206) 883-1900
Ecova Corporation
3820 159th Avenue NE
Redmond, WA 98052

Figure C.1-1. Slurry-phase biodegradation.

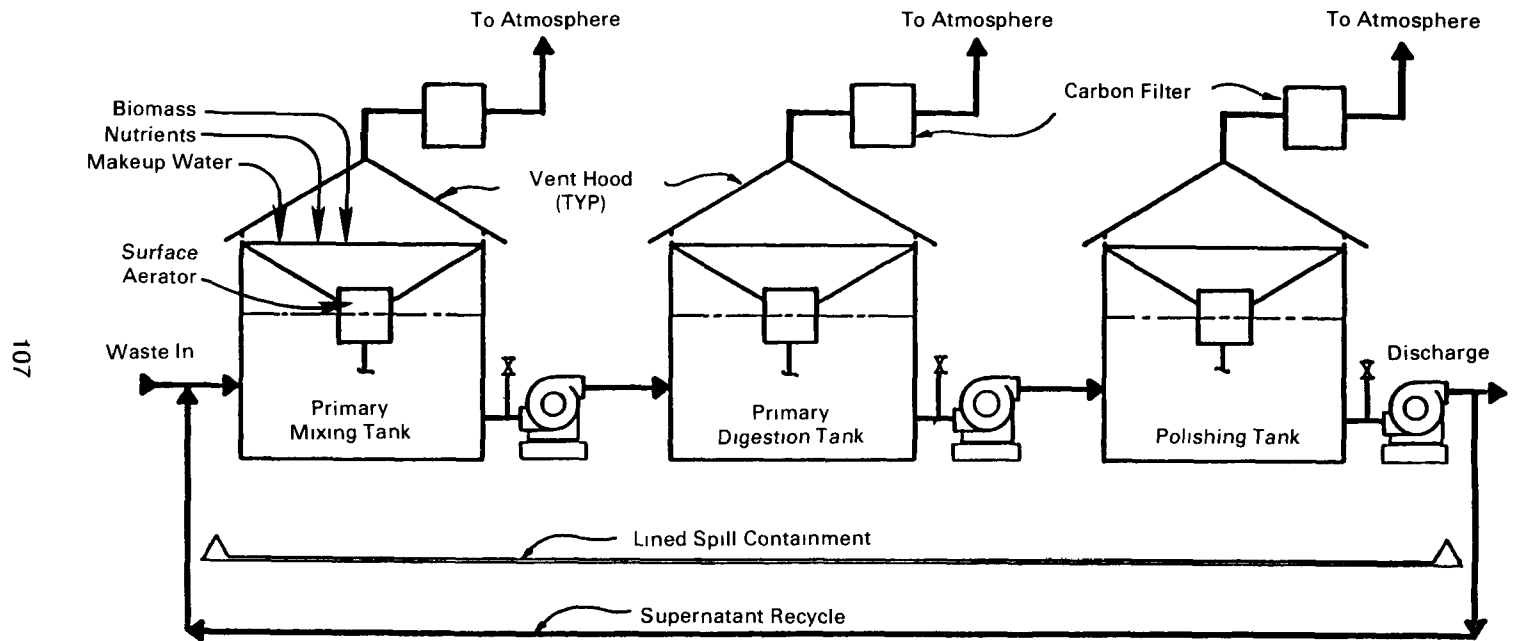

Source: MoTec, Inc.

Figure C.1-2. Solid phase biodegradation.

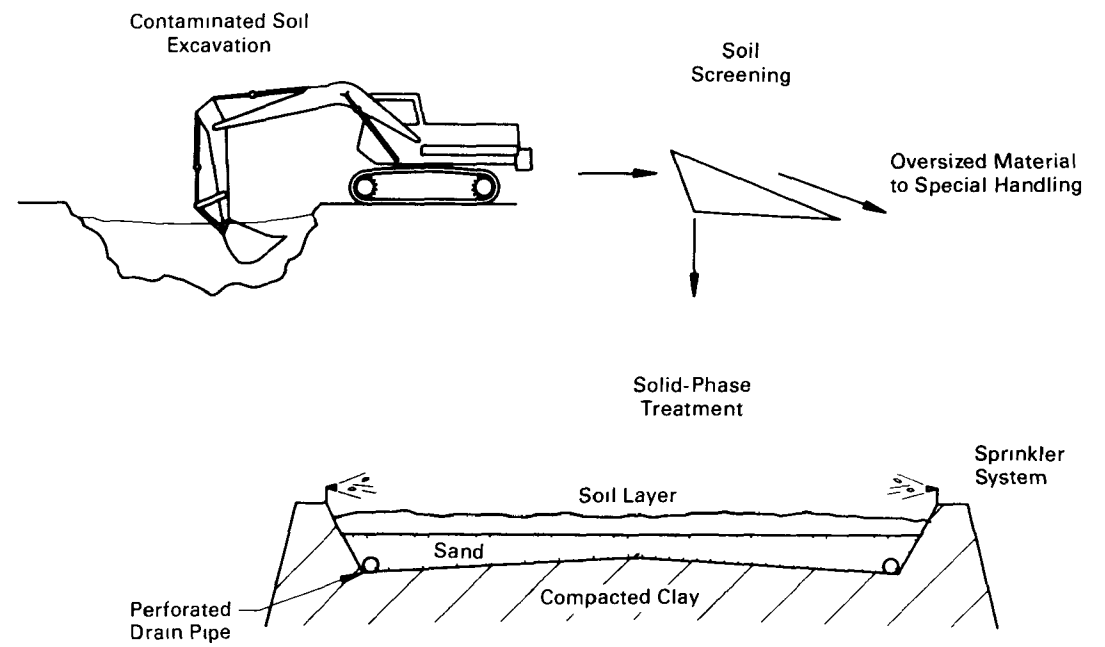

Table C.1-1 Technology Summary.**Waste Type: Soils and Sludges**
Technology: Biodegradation

Characteristics Impacting Process Feasibility	Reason for Potential Impact	Data Collection Requirements	Ref.
Variable waste composition	Inconsistent biodegradation caused by variation in biological activity.	Waste composition	1
Water solubility	Contaminants with low solubility are harder to biodegrade.	Solubility	1
Biodegradability	Low biodegradability inhibits process.	Chemical constituents, bench-scale testing	1
Temperature outside 15-70°C range	Larger, more diverse microbial population present in this range.	Temperature monitoring	1,2
Nutrient deficiency	Lack of adequate nutrients for biological activity (although nutrient supplements may be added).	C/N/P ratio	3
Oxygen deficiency	Lack of oxygen is rate limiting.	Oxygen monitoring	1
Moisture content	A moisture content of greater than 79% affects bacterial activity and availability of oxygen. A moisture content below 40% severely inhibits bacterial activity.	Ratio of air to water in interstices, porosity of composting mass	1,2,3
pH outside 4.5-8.5 range	Inhibition of biological activity	Sludge pH testing	
Microbial population	If indigenous microorganisms not present, cultured strains can be added.	Culture test	3
Water and air emissions and discharges (composting only)	Potential environmental and/or health impacts (control achieved through air scrubbing, carbon filtration, forced aeration, cement liner).	Concentrations of contaminants	1

Table C.1-1 Technology Summary (continued).

Waste Type: Soils and Sludges
Technology: Biodegradation

<i>Characteristics Impacting Process Feasibility</i>	<i>Reason for Potential Impact</i>	<i>Data Collection Requirements</i>	<i>Ref.</i>
<i>Compaction of compost (composting only)</i>	<i>Particles tend to coalesce and form an amorphous mass that is not easily maintained in an aerobic environment (wood chips or shredded tires may be added as bulking agents).</i>	<i>Determine integrity, physical nature of material</i>	<i>3</i>
<i>Nonuniform particle (composting only)</i>	<i>Waste mixtures must be of uniform particle size.</i>	<i>Particle size distribution</i>	<i>2</i>
<i>Presence of elevated levels of:</i> <ul style="list-style-type: none"> ● <i>Heavy metals</i> ● <i>Highly chlorinated organics</i> ● <i>Some pesticides, herbicides</i> ● <i>Inorganic salts</i> 	<i>Can be highly toxic to microorganisms.</i>	<i>Analysis for priority pollutant</i>	<i>4,5</i>

C.2 In Situ Biodegradation

Technology Description

In situ biodegradation uses indigenous or introduced aerobic or anaerobic bacteria to biodegrade organic compounds in soils. The technology involves enhancing the natural biodegradation process by injecting nutrients (i.e., phosphorus, nitrogen, etc.), oxygen, and even cultured bacterial strains. It is also possible to adjust some environmental parameters such as soil pH and temperature.

In situ biodegradation is often used in conjunction with a ground-water pumping and reinjection system to circulate nutrients and oxygen through a contaminated aquifer and associated soils. It can provide substantial reduction in organic contaminant levels in soils without the cost of soil excavation.

Under favorable conditions indigenous and/or introduced soil microorganisms are known to degrade many organic compounds. Microorganisms are capable of completely degrading organic compounds into water and carbon dioxide in the presence of sufficient oxygen and nutrients such as nitrogen and phosphorous, a near neutral pH, and warmer soil temperatures. Anaerobic degradation of organics is possible although the rates of degradation are generally too slow to constitute an active remediation.

Enhanced biodegradation (bioreclamation) is one of the in situ methods that is engineered to create favorable aerobic conditions in unfavorable conditions such as nonhomogeneous soils, delicate geochemical balances, and uncertain organic substrates. A major rate limiting factor in in situ biodegradation is the presence of dissolved oxygen. Hydrogen peroxide is currently the preferred oxygen source; at 40 mg/l of ground water, it releases enough oxygen to maintain continuous biodegradation. The presence of iron in the subsurface causes hydrogen peroxide depletion at a faster rate. A prerequisite for the application of hydrogen peroxide as an oxygen source is soil pretreatment, which is necessary to prolong the stability of peroxide in situ. Several phosphate compounds are currently being tested as complexing agents for iron to increase the stability of peroxide. Anaerobic pathways are also available but are generally considered too slow to constitute active cleanup.

It is recommended that a control area be established on the upgradient end of the site. The purpose of this area is to compare natural levels of degradation to the enhanced biodegradation reaction provided by nutrient and peroxide additions. An aeration and settling unit may be required to reduce iron fouling if the iron content of the shallow ground water is greater than 10 mg/l.

This technology is not suitable for soil contaminated with metals present in inhibitory concentrations but is well suited for soil contaminated by petroleum by-products.

Status: Ecova has applied this technology to solvents and chlorinated aromatic compounds. The technology has been used most frequently to treat soil contaminated with gasoline and diesel.

Figure C.2-1 is an illustration of in situ biodegradation, and Table C.2-1 is a technology restriction table.

EPA Contact:

John Wilson, (405) 332-8800, FTS 743-2259
U.S. Environmental Protection Agency
Robert S. Kerr Environmental Research Laboratory
Ada, OK 74820

Vendors:

Al Bourquin, (206) 883-1900
Derek Ross, (206) 883-1900
Ecova Corporation
3820 159th Avenue NE
Redmond, WA 98052

John Kopper, (201) 225-2000
IT Corporation
165 Fieldcrest Avenue
Edison, NJ 08818

Paul B. Trost, (303) 279-4255
MTA Remedial Resources, Incorporated
1511 Washington Avenue
Golden CO 80401

Figure C.2-1. In situ bioremediation.

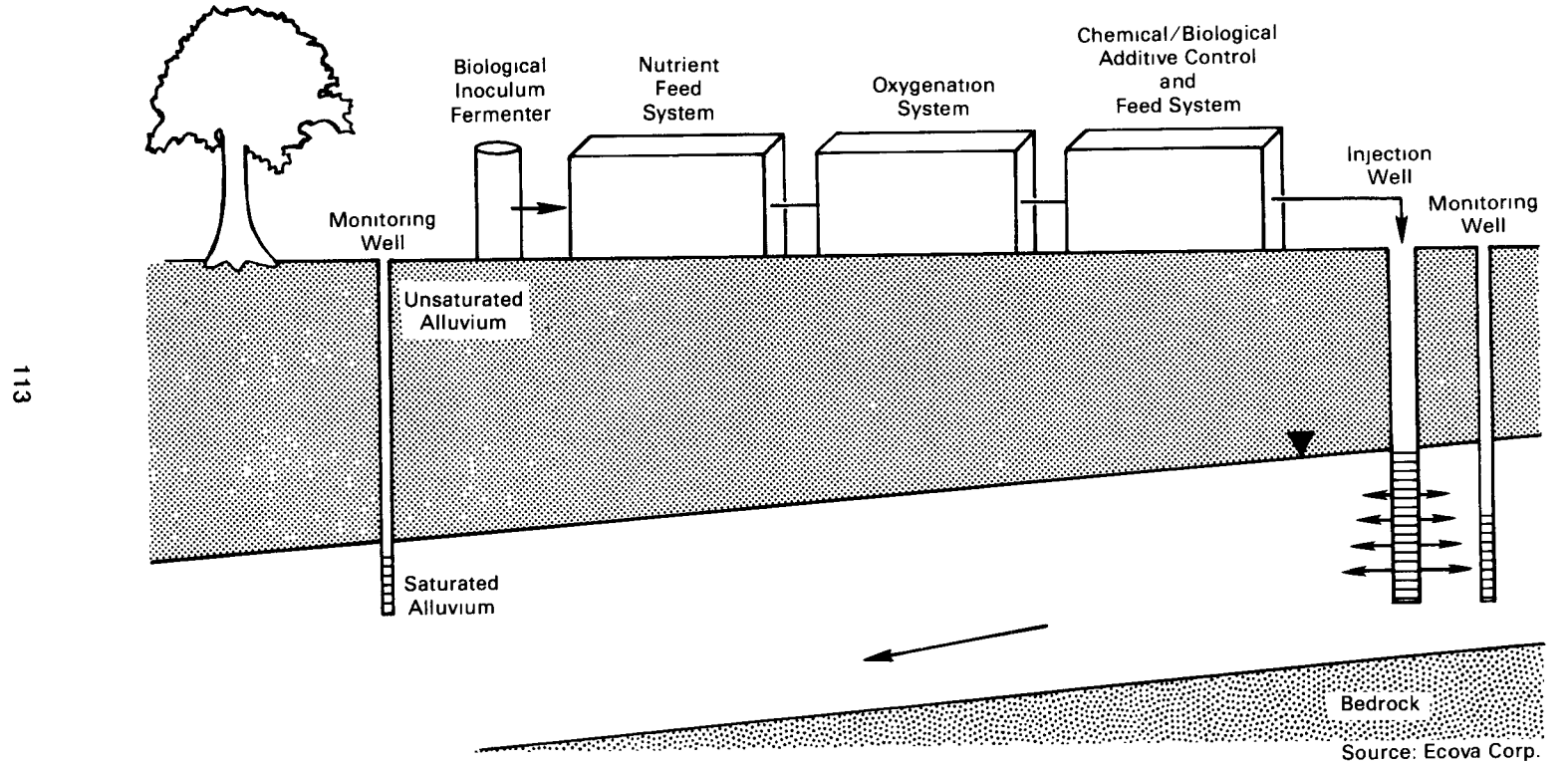

Table C.2-1 Technology Summary.

Waste Type: Soils and Sludges
Technology: In Situ Biodegradation

<i>Characteristics Impacting Process Feasibility</i>	<i>Reason for Potential Impact</i>	<i>Data Collection Requirements</i>	<i>Ref.</i>
Variable waste composition	Inconsistent biodegradation caused by variation in biological activity.	Waste composition	1
Water solubility	Contaminants with low solubility are harder to biodegrade.	Solubility	1
Biodegradability	Low biodegradability inhibits process.	Chemical constituents, presence of metals/salts, bench-scale testing	1
Temperature outside 25-70°C range	Larger, more diverse microbial population present in this range.	Temperature monitoring	1,2
Nutrient deficiency	Lack of adequate nutrients for biological activity (although nutrient supplements may be added).	C/N/S ratio	3
Oxygen deficiency	Oxygen depletion slows down the process.	Oxygen monitoring	1
Moisture content	A moisture content of greater than 79% affects bacterial activity and availability of oxygen. A moisture content below 40% severely inhibits bacterial activity.	Ratio of air to water in interstices, porosity of composting mass	1,2,3
pH outside 4.5-7.5 range	Inhibition of biological activity.	Sludge pH testing	
Microbial population	If indigenous microorganisms not present, cultured strains can be added.	Culture test	3
Presence of elevated levels of: <ul style="list-style-type: none"> ● Heavy metals ● Highly chlorinated organics ● Some pesticides, herbicides ● Inorganic salts 	Can be highly toxic to microorganisms.	Analysis for contaminants	4,5

Table C.2-1 Technology Summary (continued).

Waste Type: Soils and Sludges
Technology: In Situ Biodegradation

<i>Characteristics Impacting Process Feasibility</i>	<i>Reason for Potential Impact</i>	<i>Data Collection Requirements</i>	<i>Ref.</i>
<i>Unfavorable soil characteristics</i>			
● <i>Low permeability</i>	<i>Hinders movement of water and nutrients through contaminated area.</i>	<i>Percolation testing</i>	<i>4,5</i>
● <i>Variable soil conditions</i>	<i>Inconsistent biodegradation due to variation in biological activity.</i>	<i>Soil mapping</i>	<i>4</i>
● <i>Low soil pH (< 5.5)</i>	<i>Inhibition of biological activity.</i>	<i>Soil pH testing</i>	<i>4</i>
● <i>Low soil organic content</i>	<i>Lack of organic substrate for biological growth</i>	<i>Soil humus content</i>	<i>4</i>
● <i>Low moisture content (< 10%)</i>	<i>Subsurface biological growth requires adequate moisture.</i>	<i>Soil moisture content</i>	<i>4</i>
<i>Unfavorable site hydrology</i>	<i>Groundwater flow patterns must permit pumping for extraction and reinjection.</i>	<i>Site hydrogeology must be well defined.</i>	<i>4,5</i>
<i>Unfavorable groundwater quality parameters</i>			
● <i>Low dissolved oxygen</i>	<i>Oxygen necessary for biological growth.</i>	<i>Dissolved oxygen in ground water, determine amount of hydrogen peroxide needed to satisfy oxygen demand</i>	<i>4,5</i>
● <i>Low pH, alkalinity</i>	<i>Inhibition of biological activity.</i>	<i>pH and alkalinity of ground water</i>	<i>4,5</i>

References

- (1) USEPA. 1985. U.S. Environmental Protection Agency, Office of Research and Development. 1985 *handbook - remedial action at waste disposal sites*. Hazardous Waste Engineering Research Laboratory, Office of Research and Development. #625-6-85-006. Cincinnati, Ohio: U.S. Environmental Protection Agency.
- (2) Versar Inc. 1985. Assessment of treatment technologies for hazardous waste and their restrictive waste characteristics. Vol. 1A-D. Washington, D.C.: U.S. Environmental Protection Agency.
- (3) CDM, Inc. 1985. Alternative treatment technologies for Superfund wastes. Prepared for U.S. Environmental Protection Agency, Office of Solid Waste. U.S. Environmental Protection Agency, Contract No. 68-01-7953. Washington, D.C.: U.S. Environmental Protection Agency.
- (4) USEPA. 1986. U.S. Environmental Protection Agency, Office of Solid Waste and Emergency Response. *Mobile treatment technologies for Superfund wastes*. #540/2-86/003(f). Washington, D.C.: U.S. Environmental Protection Agency.
- (5) USEPA. 1986. U.S. Environmental Protection Agency, Office of Solid Waste and Emergency Response. *Superfund treatment technologies: a vendor inventory*. #540/2-86/004. Washington, D.C.: U.S. Environmental Protection Agency.

Appendix D
Selected Reference Tables

Table D-1 Examples of Constituents Within Waste Groups.

HALOGENATED VOLATILES	HALOGENATED SEMIVOLATILES (cont)
Bromodichloromethane	Bis(2-chloroethoxy)phthalate
Bromoform	Bis(2-chloroethoxy)ether
Bromomethane	1,2-bis(2-chloroethoxy)ethane
Carbon tetrachloride	NONHALOGENATED VOLATILES
Chlorodibromomethane	Acetone
Chlorobenzene	Acrolein
Chloroethane	Acrylonitrile
Chloroform	Benzene
Chloromethane	2-butanone
Chloropropane	Carbon disulfide
Dibromomethane	Cyclohexanone
Cis,1,3-dichloropropene	Ethyl acetate
1,1-Dichloroethane	Ethyl ether
1,2-Dichloroethane	Ethyl benzene
1,1-Dichloroethene	2-hexanone
1,2-Dichloroethene	Isobutanol
1,2-Dichloropropane	Methanol
Fluorotrichloromethane	Methyl isobutyl ketone
Methylene chloride	4-methyl-2-pentanone
1,1,2,2-tetrachloroethane	n-butyl alcohol
Tetrachloroethene	Styrene
1,1,1-Trichloroethane	Toluene
1,1,2-Trichloroethane	Trimethyl benzene
1,2-Trans-dichloroethene	Vinyl acetate
Trans-1,3-dichloropropene	Xylenes
1,1,2-trichloro-1,2,2-trifluoroethane	NONHALOGENATED SEMIVOLATILES
Trichloroethene	Benzoic acid
Vinyl chloride	Cresols
Total chlorinated hydrocarbons	2,4-dimethylphenol
Hexachloroethane	2,4-dinitrophenol
Dichloromethane	2-methylphenol
HALOGENATED SEMIVOLATILES	4-methylphenol
2-chlorophenol	2-nitrophenol
2,4-dichlorophenol	4-nitrophenol
Hexachlorocyclopentadiene	Phenol
p-chloro-m-cresol	Acenaphthene
Pentachlorophenol	Acenaphthylene
Tetrachlorophenol	Anthracene
2,4,5-trichlorophenol	Benzidine
2,4,6-trichlorophenol	Benzo(a)anthracene
Bis-(2-chloroethoxy)methane	Benzo(b)fluoranthene
Bis(2-chloroethyl)ether	Benzo(k)fluoranthene
Bis(2-chloroisopropyl)ether	Benzo(a)pyrene
4-bromophenyl phenyl ether	Benzo(ghi)perylene
4-chloroaniline	Benzyl alcohol
2-chloronaphthalene	Bis(2-ethylhexyl)phthalate
4-chlorophenyl phenylether	Butyl benzyl phthalate
1,2-dichlorobenzene	Chrysene
1,3-dichlorobenzene	Dibenzo(a,h)anthracene
1,4-dichlorobenzene	Dibenzofuran
3,3-dichlorobenzidine	Diethyl phthalate
Hexachlorobenzene	Dimethyl phthalate
Hexachlorobutadiene	Di-n-butyl phthalate
1,2,4-trichlorobenzene	

Table D-1 Examples of Constituents Within Waste Groups (continued).

4,6-dinitro-2-methylphenol	VOLATILE METALS (cont)
2,4-dinitrotoluene	Lead
2,6-dinitrotoluene	Mercury
Di-n-octyl phthalate	Tin
1,2-diphenylhydrazine	Selenium
Fluoranthene	
Fluorene	OTHER CATEGORIES
Indeno(1,2,3-cd)pyrene	Asbestos
Isophorone	
2-methylnaphthalene	INORGANIC CORROSIVES
Napthalene	Hydrochloric acid
2-nitroaniline	Nitric acid
3-nitroaniline	Hydrofluoric acid
4-nitroaniline	Sulfuric acid
Nitrobenzene	Sodium hydroxide
n-nitrosodimethylamine	Calcium hydroxide
n-nitrosodi-n-propylamine	Calcium carbonate
n-nitrosodiphenylamine	Potassium carbonate
Phenanthrene	
Pyrene	PCBs
Pyridine	PCB (Arochlor)-1016
2-methynaphthalene	PCB (Arochlor)-1221
Bis phthalate	PCB (Arochlor)-1232
Phenyl napthalene	PCB (Arochlor)-1242
	PCB (Arochlor)-1248
	PCB (Arochlor)-1254
	PCB (Arochlor)-1260
	PCB NOS (not otherwise specified)
PESTICIDES	ORGANIC CORROSIVES
Aldrin	Acetic acid
Bhc-alpha	Acetyl chloride
Bhc-beta	Aniline
Bhc-delta	Aromatic Sulfonic acids
Bhc-gamma	Cresylic acid
Chlordane	Formic acid
4,4'-DDD	
4,4'-DDE	
4,4'-DDt	
Dieldrin	
Endosulfan I	NONMETALLIC TOXIC ELEMENTS
Endosulfan II	Fluorine
Endosulfan sulfate	Bismuth
Endrin	
Endrin aldehyde	
Ethion	NONVOLATILE METALS
Ethyl parathion	Aluminum
Heptachlor	Antimony
Heptachlor epoxide	Barium
Malathion	Beryllium
Methylparathion	Bismuth
Parathion	Cadmium
Toxaphene	Calcium
	Chromium
	Copper
	Cobalt
VOLATILE METALS	Iron
Arsenic	Magnesium
Bismuth	

Table D-1 Examples of Constituents Within Waste Groups (continued).

<i>NONVOLATILE METALS (cont)</i>	<i>ORGANIC CYANIDES</i>
<i>Manganese</i>	<i>Organonitriles</i>
<i>Nickel</i>	
<i>Potassium</i>	<i>INORGANIC CYANIDES</i>
<i>Selenium</i>	<i>Cyanide</i>
<i>Sodium</i>	<i>Metallic cyanides</i>
<i>Vanadium</i>	<i>(e.g., ferricyanide,</i>
<i>Zinc</i>	<i>sodium cyanide)</i>
<i>RADIOACTIVES</i>	<i>OXIDIZERS</i>
<i>Radioactive isotopes of</i>	<i>Chlorates</i>
<i>iodine, barium, uranium</i>	<i>Chromates</i>
<i>Radium</i>	
<i>Gamma radioactivity</i>	<i>REDUCERS</i>
<i>Radon; alpha radioactivity</i>	<i>Sulfides</i>
	<i>Phosphides</i>
	<i>Hydrazine</i>

Table D-2 Waste Technology Matrix: Soils.

Contaminant		Technology																	
		A.1-1	A.2-1	A.3-1	A.5-1	A.6-1	B.1-1	B.2-1	B.3-1	B.4-1	B.5-1	B.6-1	B.7-1	B.8-1	B.10-1	C.1-1	C.2-1		
Organic	Halogenated volatiles	●	●	●	●	●	●	●	●	●	●	●	●	●	●	●	●	●	
	Halogenated semivolatiles	●	●	●	●	●	●	●	●	●	●	●	●	●	●	●	●	●	
	Nonhalogenated volatiles	●	●	●	●	●	●	●	●	●	●	●	●	●	●	●	●	●	
	Nonhalogenated semivolatiles	●	●	●	●	●	●	●	●	●	●	●	●	●	●	●	●	●	
	PCBs	●	●	●	●	●	●	●	●	●	●	●	●	●	●	●	●	●	
	Pesticides	●	●	●	●	●	●	●	●	●	●	●	●	●	●	●	●	●	
	Organic cyanides	●	●	●	●	●	●	●	●	●	●	●	●	●	●	●	●	●	
	Organic corrosives	●	●	●	●	●	●	●	●	●	●	●	●	●	●	●	●	●	
	Inorganic	Volatile metals	×	×	×	○	×	○	○	○	○	○	○	○	○	○	○	○	○
		Nonvolatile metals	○	○	○	○	○	○	○	○	○	○	○	○	○	○	○	○	○
Asbestos		○	○	○	○	○	○	○	○	○	○	○	○	○	○	○	○	○	
Radioactive materials		○	○	○	○	○	○	○	○	○	○	○	○	○	○	○	○	○	
Inorganic corrosives		○	○	○	○	○	○	○	○	○	○	○	○	○	○	○	○	○	
Inorganic cyanides		○	○	○	○	○	○	○	○	○	○	○	○	○	○	○	○	○	
Reactive	Oxidizers	○	○	○	○	○	○	○	○	○	○	○	○	○	○	○	○	○	
	Reducers	○	○	○	○	○	○	○	○	○	○	○	○	○	○	○	○	○	

● Demonstrated effectiveness
 ○ Potential effectiveness
 ○ No effectiveness
 × Potential adverse impacts to process or environment

* Do not use this matrix table alone. Please refer to the cited appendices for guidance.

Table D-3 Waste Technology Matrix: Sludges.

Contaminant		Technology														
		A.1-1	A.2-1	A.3-1	A.4-1	A.5-1	A.6-1	B.1-1	B.2-1	B.5-1	B.8-1	B.9-1	B.10-1	C.1-1	C.2-1	
Organic	Table	Fluidized bed incineration	Rotary kiln incineration	Infrared thermal treatment	Wet air oxidation	Pyrolysis-incineration	Vitrification	Chemical extraction	In situ chemical treatment	Glycolate dechlorination	Stabilization/solidification	Chemical reduction oxidation	In situ vitrification	Biodegradation	In situ biodegradation	
	Halogenated volatiles	●	●	●	●	●	●	●	○	●	●	●	●	●	●	●
	Halogenated semivolatiles	●	●	●	●	●	●	●	○	●	●	●	●	●	●	●
	Nonhalogenated volatiles	●	●	●	●	●	●	●	○	●	●	●	●	●	●	●
	Nonhalogenated semivolatiles	●	●	●	●	●	●	●	○	●	●	●	●	●	●	●
	PCBs	●	●	●	●	●	●	●	○	●	●	●	●	●	●	●
	Pesticides	●	●	●	●	●	●	●	○	●	●	●	●	●	●	●
	Organic cyanide	●	●	●	●	●	●	●	○	●	●	●	●	●	●	●
	Organic corrosives	●	●	●	●	●	●	●	○	●	●	○	○	○	○	○
	Inorganic	Volatile metals	×	×	×	○	○	×	○	○	○	○	○	○	○	○
Nonvolatile metals		○	○	○	○	○	○	○	○	○	○	○	○	○	○	
Asbestos		○	○	○	○	○	○	○	○	○	○	○	○	○	○	
Radioactive materials		○	○	○	○	○	○	○	○	○	○	○	○	○	○	
Inorganic corrosives		○	○	○	○	○	○	○	○	○	○	○	○	○	○	
Inorganic cyanides		○	○	○	○	○	○	○	○	○	○	○	○	○	○	
Reactive	Oxidizers	●	●	○	○	○	○	○	○	○	○	○	○	○	○	
	Reducers	●	●	●	●	●	●	○	○	○	○	○	○	○	○	

- Demonstrated effectiveness
- ◐ Potential effectiveness
- No effectiveness
- × Potential adverse impacts to process or environment

* Do not use this matrix table alone. Please refer to the cited appendices for guidance.

Table D-4 Pretreatment/Materials Handling Table: Sludges.

<i>Problem</i>	<i>Treatment/Solution</i>	
<i>Material transport and excavation</i>	<i>Dragline</i>	<i>Crane-operated excavator bucket to dredge or scrape sludge from lagoons, ponds, or pits.</i>
	<i>Backhoes, excavators</i>	<i>Useful for subsurface excavation or at the original ground level.</i>
	<i>Mudcat</i>	<i>Bulldozer or loader much like a crawler capable of moving through sludge.</i>
	<i>Positive displacement pump (e.g., cement pump)</i>	<i>Pump that can handle high-density sludges containing abrasives such as sand and gravel.</i>
	<i>Moyno pump</i>	<i>Progressing cavity pump that can pump high-viscosity sludges.</i>
<i>Excessive water content</i>	<i>Evaporator</i>	<i>Excess water can be evaporated from sludge. The Carver-Greenfield process is a potentially applicable technology. The sludge is mixed with oil to form a slurry, and the moisture is evaporated through a multiple-effect evaporator.</i>
	<i>Filter press</i>	<i>Sludge is pumped into cavities formed by a series of plates covered by a filter cloth. The liquid seeps through the filter cloth, and the sludge solids remain.</i>
	<i>Belt filter</i>	<i>Sludge drops onto a perforated belt, where gravity drainage takes place. The thickened sludge is pressed between a series of rollers to produce a dry cake.</i>
	<i>Vacuum filter</i>	<i>Sludge is fed onto a rotating perforated drum with an internal vacuum, which extracts liquid phase.</i>
	<i>Centrifuge (solid bowl)</i>	<i>Sludge feeds through a central pipe that sprays it into a rotating bowl. Centrate escapes out the large end of the bowl, and the solids are removed from the tapered end of the bowl by means of a screw conveyer.</i>
	<i>Drying</i>	<i>Rotary drying, flash drying, sand bed.</i>
	<i>Gravity thickening</i>	<i>Slurry enters thickener and settles into circular tank. The sludge thickens and compacts at the bottom of the tank, and the sludge blanket remains to help further concentration.</i>
	<i>Chemical addition</i>	<i>Compounds may be added to physically or chemically bind water</i>

Table D-4 Pretreatment/Materials Handling Table: Sludges (continued).

<i>Problem</i>	<i>Treatment/Solution</i>	
Excessive sludge viscosity	Slurry	Addition of water or solvent. Addition of dispersants
Extreme pH	Neutralization	Lime, an alkaline material, is widely used for neutralizing acid wastes; sulfuric acid is used to neutralize alkaline wastes.
Oversized material. removal, disaggregation, sorting	See Table 5 (Soils)	

Table D-5 Pretreatment/Materials Handling Table: Soils.

<i>Problem</i>	<i>Treatment/Solution</i>	
Material transport and excavation	Dragline	Crane-operated excavator bucket to dredge or scrape soil to depths and farther reaches..
	Backhoes	Useful for subsurface excavation or at the original ground level.
	Heavy earthmoving equipment	Includes bulldozers, excavators, and dump trucks for excavation and transport.
	Conveyers	May be useful for large-volume transport or feed to treatment unit.
Oversized material removal, disaggregation, sorting	Vibrating screen	Vibrates for screening of fine particles from dry materials. There is a large capacity per area of screen, and high efficiency. Can be clogged by very wet material.
	Static screen	A wedge bar screen consists of parallel bars that are frame-mounted. A slurry flows down through the feed inlet and flows tangentially down the surface of the screen. The curved surfaces of the screen and the velocity of the slurry provide a centrifugal force that separates small particles.
	Grizzlies	Parallel bars that are frame-mounted at an angle to promote materials flow and separation. Grizzlies are used to remove a small amount of oversized material from predominantly fine soil.
	Hammer mill	Used to reduce particle size of softer materials.

Table D-5 Pretreatment/Materials Handling Table: Soils (continued).

<i>Problem</i>		<i>Treatment/Solution</i>
<i>Oversized material removal, disaggregation, sorting (cont.)</i>	<i>Impact crushers</i>	<i>Break up feed particles by impact with rotating hammers or bars. Impact crushing works best with material that has several planes of weakness, such as impurities or cracks.</i>
	<i>Shredder</i>	<i>Reduces size of waste material. Shredders are available to handle most materials, including tires, metal, scrap, wood, and concrete.</i>
	<i>Tumbling mill</i>	<i>Reduces size of rock and other materials using a rotating drum filled with balls, rods, tubes, or pebbles.</i>
	<i>Cyclone</i>	<i>Separates different sized particles by centrifugation and gravity.</i>
<i>Fugitive emissions</i>	<i>Dust suppressant</i>	<i>Natural (e.g., water) or synthetic materials that strengthen bonds between soil particles.</i>
	<i>Negative pressure air systems</i>	<i>Vacuum systems that may be used to collect vapors and/or dust particles and prevent release into atmosphere.</i>
	<i>Foams</i>	<i>Applied to soil surface to control volatile emissions and dust during excavation</i>
	<i>Covered shelters</i>	<i>Temporary shelter with structurally or air supported cover to restrict emissions to enclosed volume.</i>
<i>Dewatering</i>	<i>Belt filter press, centrifuge</i>	<i>Useful for dewatering of very wet soils (lagoon sediments, wetlands).</i>
	<i>Rotating dryer</i>	<i>Additional drying may permit higher feed rates for thermal treatment systems.</i>

Table D-6 Residuals Management.

<i>Residual</i>	<i>Technology Generating Residual</i>	<i>Contaminants</i>	<i>Potential Management</i>
<i>Treated soil or ash</i>	<i>Fluidized bed incineration, infrared thermal treatment, rotary kiln incineration</i>	<i>Metals</i>	<i>Stabilization/solidification Vitrification</i>
<i>Treated soil</i>	<i>Low-temperature thermal stripping</i>	<i>Metals, nonvolatile organics</i>	<i>Stabilization/solidification Vitrification</i>
<i>Afterburner ash</i>	<i>Low-temperature thermal stripping</i>	<i>Volatile metals</i>	<i>Stabilization/solidification Vitrification</i>
<i>Solids (ash)</i>	<i>Wet air oxidation</i>	<i>Metal oxides, insoluble salts</i>	<i>Mechanical dewatering Stabilization/solidification</i>
<i>Glass residue</i>	<i>Vitrification</i>	<i>Nonvolatile metals at the operating temperature</i>	<i>Disposal</i>
<i>Solids</i>	<i>Chemical extraction - basic extractive sludge treatment</i>	<i>Metals, trace organics</i>	<i>Stabilization/solidification Vitrification</i>
<i>Spent activated carbon</i>	<i>Low-temperature thermal stripping, air pollution control device, wastewater treatment</i>	<i>Volatile organics</i>	<i>Incineration, thermal regeneration, wet air oxidation, steam stripping with water treatment, biodegradation</i>
<i>Fly ash</i>	<i>Electrostatic precipitator, baghouse, cyclone</i>	<i>Volatile metals</i>	<i>Stabilization/solidification, recycle to primary thermal unit, reuse of ash</i>
<i>Leachate</i>	<i>Biodegradation, stabilization/solidification</i>	<i>Trace metals</i>	<i>Chemical precipitation Stabilization/solidification</i>
		<i>Trace organics</i>	<i>Biological treatment or carbon adsorption, photooxidation, chemical oxidation</i>
<i>Aqueous effluent</i>	<i>Chemical extraction, soil washing</i>	<i>Trace organics</i>	<i>Biological treatment or carbon adsorption</i>
	<i>Wet air oxidation</i>	<i>Carboxylic acids and other carbonyl group compounds; low molecular weight organics, such as acetaldehyde, acetone, methanol</i>	<i>Biological treatment or carbon adsorption, photooxidation, chemical oxidation</i>

Table D-6 Residuals Management (continued).

<i>Residual</i>	<i>Technology Generating Residual</i>	<i>Contaminants</i>	<i>Potential Management</i>
<i>Water/ reagent mix</i>	<i>Glycolate dechlorination</i>	<i>Organics</i>	<i>Distillation followed by incineration</i>
<i>Water/ flushing agent mix</i>	<i>Soil washing/ soil flushing</i>	<i>Organics</i>	<i>Distillation, carbon adsorption, biological treatment, chemical oxidation, photochemical oxidation</i>
		<i>Metals</i>	<i>Chemical precipitation</i>
		<i>Cyanides</i>	<i>Chemical oxidation, wet air oxidation, electrolytic oxidation, photochemical oxidation</i>
<i>Organic effluent</i>	<i>Solvent extraction</i>	<i>Organics (non- PCBs)</i> <i>Organics mixed with PCBs</i>	<i>Recycle or reuse as fuel Incineration</i>
<i>Scrubber water</i>	<i>Incineration (fluidized bed incineration, rotary kiln incineration, vitrification unit, infrared thermal treatment), off-gas collection and treatment</i>	<i>Caustic, high chloride content, volatile metals, organics, metal particulates, and inorganic particulates</i>	<i>Neutralization, chemical precipitation, reverse osmosis, settling ponds, evaporation ponds, filtration, and gas phase incineration of organics, chemical oxidation, photochemical oxidation</i>
<i>Off-gas</i>	<i>In situ vitrification</i>	<i>Trace levels of combustion products, volatile metals, and/or volatile organics</i>	<i>Gas scrubber, activated carbon adsorption</i>
	<i>Stabilization/ solidification</i>	<i>Ammonia Volatile organics</i>	<i>Gas scrubber Carbon adsorption</i>
	<i>Wet air oxidation</i>	<i>Low molecular weight compounds, such as acetaldehyde, acetone, acetic acid, methanol</i>	<i>Gas scrubber, carbon adsorption, fume incineration, biological treatment</i>